



(86) 1996/06/04

(87) 1996/12/12

(45) 2001/05/08

(72) THAL, Raymond, US

(73) THAL, Raymond, US

(51) Int.Cl.⁶ A61B 17/04

(30) 1995/06/06 (08/471,508) US

(30) 1995/11/01 (08/551,648) US

(54) **DISPOSITIF D'ANCRAGE POUR SUTURE SANS NOEUD**

(54) **KNOTLESS SUTURE ANCHOR ASSEMBLY**

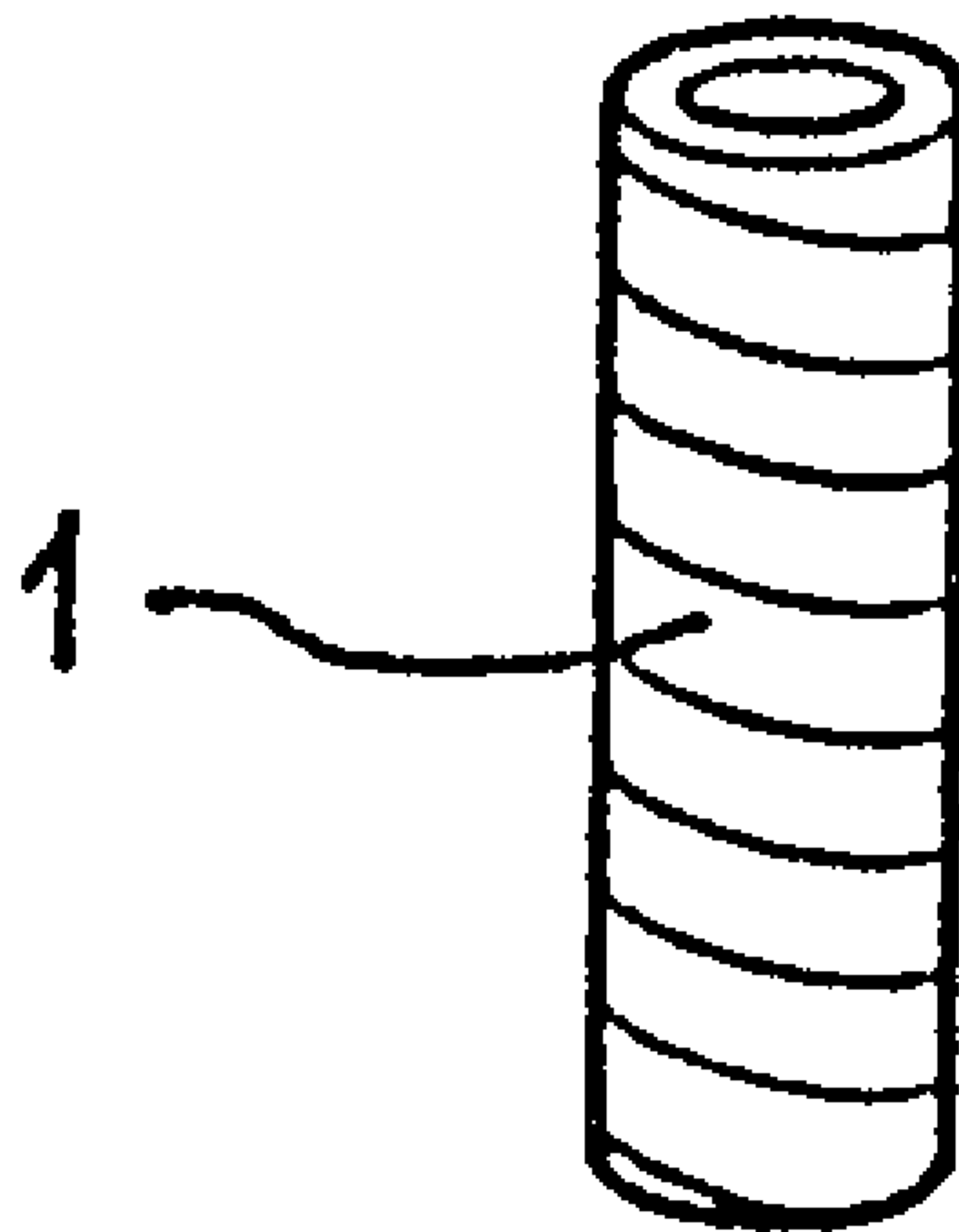

(57) L'invention porte sur un dispositif d'ancrage pour suture sans noeud une pièce (150) ou deux pièces (66, 68) servant à fixer ou à refixer un tissu à une masse osseuse, ou bien à le réparer. Le dispositif permet d'exécuter une intervention endoscopique ou chirurgicale ouverte sans avoir besoin de faire un noeud pour refixer des tissus à une masse osseuse. Dans un modèle, un perforateur (158) est inséré dans les tissus, puis dans une masse osseuse. Il est attaché ou fixé solidement à la gaine d'ancrage (66) au moyen d'un mécanisme d'encliquetage, tirant ou collant ainsi le tissu à la masse osseuse.

(57) This invention is a one-piece (150) or two-piece (66, 68) knotless suture anchor assembly for the attachment or reattachment or repair of tissue to a bone mass. The assembly allows for an endoscopic or open surgical procedure to take place without the requirement of tying a knot for reattachment of tissue to bone mass. In one embodiment, a spike member (158) is inserted through tissue and then inserted into a bone mass. The spike member is securely fastened or attached to the anchoring sleeve (66) with a ratchet mechanism thereby pulling or adhering the tissue to the bone mass.

ABSTRACT

This invention is a one-piece (150) or two-piece (66, 68) knotless suture anchor assembly for the attachment or reattachment or repair of tissue to a bone mass. The assembly allows for an endoscopic or open surgical procedure to take place without the requirement of tying a knot for reattachment of tissue to bone mass. In one embodiment, a spike member (158) is inserted through tissue and then inserted into a bone mass. The spike member is securely fastened or attached to the anchoring sleeve (66) with a ratchet mechanism thereby pulling or adhering the tissue to the bone mass.

5

10

KNOTLESS SUTURE ANCHOR ASSEMBLY
BACKGROUND OF THE INVENTION

1. Field of the Invention

5 The present invention relates to devices or assemblies used in tissue repair. More particularly, the assembly enables the attachment together or repair of portions of biological tissue (i.e., tendons or ligaments) onto a bone surface.

10 2. Description of the Background Art

 Soft tissues, such as tendons and ligaments, generally are attached to bone by small collagenous fibers. These connections are strong but permit the tendons and ligaments to be flexible. When a tissue is torn away from the bone and requires repair, a surgeon is often required to repair the detached soft tissue with sutures which are passed through bone tunnels and tied. A number of devices have been developed for securing a ligament or tendon to a bone mass. These devices can be used in place of bone tunnelling techniques. These attachment devices are usually inserted through extensive surgical incisions and, in some circumstances, by arthroscopic surgical techniques. The use of bone tunnels for repair can be difficult and generally require large open incisions. Recently, through the advent of endoscopic surgery, where the surgeon looks into a joint cavity with a telescope, there has been a trend to repair soft tissues back to bone through small incisions called portals. The unique knotless suture anchor assemblies described herein facilitate this difficult and precise procedure.

 A variety of devices are available for attaching objects to bone, such as screws, staples, cement, suture anchors, and sutures alone. These devices have been used to attach soft tissue, such as ligaments, tendons, muscles, as well as objects such as prostheses, to bone. A suture anchor is a device which utilizes small anchors with suture materials attached thereto. A device, such as a screw, is inserted into the bone mass and anchored in place. After insertion of the anchor, the attached suture is passed through the tissue to be repaired. The tying of a knot in the suture is then required to secure the tissue to the bone. The process of passing the anchored suture through the

soft tissue and tying a knot is time consuming and difficult to undertake in the tight space encountered during endoscopic surgery and sometimes even in conventional open surgery.

5 One example of a suture anchor assembly is disclosed in U.S. Patent No. 5,370,662, wherein an anchor assembly includes a pre-threaded suture positioned at its posterior. First the anchor is inserted into the bone mass. The attached suture is then passed through the tissue for reattachment. The surgeon is required to tie a knot with the suture to complete the surgical process. Some suture anchors can be passed through the soft tissue first and then into the bone. Most suture anchors need to be inserted into the bone first. Only after this has been accomplished can the sutures be passed through the soft tissue. Alternatives to this procedure include non-suture soft tissue anchor systems. A few of these systems, such as those disclosed in U.S. Patent Nos. 5,013,316 and 4,532,926, can be used arthroscopically but fixation with these devices may not be as secure as that achieved with sutures. Only a few points of fixation are possible with the non-suture type anchor since the device is relatively large. Therefore suture devices are more favorable. This type of non-suture staple device is disadvantageous in that it has been known to crack the bone during deployment, or accidentally transect the object being attached to the bone. In addition, the device itself has been known to crack or break during or after deployment.

15 U.S. Patent Nos. 5,037,422; 5,224,946; and 5,236,445 all disclose bone anchor configurations for attaching sutures within openings formed in bones during joint reconstructive surgery and endoscopic surgical procedures. With all these intricate procedures, the suture itself must be inserted through a tissue mass and tied with a surgical knot to repair the soft tissue to bone.

20 A primary object of the present invention is to provide a suture anchor assembly which is easy to use and install.

35 Another object of the present invention is to provide a suture anchor assembly which allows for secure attachment of

soft tissue to bone without the use or requirement of tying a knot.

5 Still another object of the present invention is to provide a suture anchor assembly which is compact and allows a surgeon to easily guide the tissue into a bone anchoring sleeve to enhance the security of the repair.

10 Still another object of the present invention is to provide an anchor assembly which allows for passage through soft tissue in a singular fashion without the need for additional instrumentation for passing the suture separately through the soft tissue to be repaired.

SUMMARY OF THE INVENTION

In accordance with the above objects, the present invention is a knotless suture anchor assembly for attachment or reattachment of biological soft tissue to bone. The unique knotless suture anchor assembly includes a hollow anchoring sleeve which is installed into a bone mass. The anchoring sleeve can have a closed pointed drill end or be totally cylindrical in shape. The hollow anchoring sleeve can be ribbed or threaded on its exterior for secure attachment to the bone or embody varying types of anchor configurations to facilitate a strong bond with the bone mass. A number of prior patents disclose configurations for the exterior of a bone anchor which are within the contemplation of the invention for use as the anchoring means for the exterior of the hollow anchoring sleeve.

U.S. Patent Nos. 4,007,743; 4,632,101; 4,721,103; 4,870,957; 4,898,156; 4,946,468; 5,084,050; 5,102,421; 5,141,520; 5,192,303; and 5,207,679 all illustrate varying exterior structures which may embody the anchoring sleeve portion of the invention. These patents disclose various means and mechanisms for anchoring a device to a bone mass thus preventing pull-out of the sleeve after insertion into bone.

Further, the hollow anchoring sleeve can contain a collar on the rear portion or rear side of the hollow anchoring sleeve to control the depth of sleeve insertion into the bone and prevent excessive insertion depth.

A second component of the knotless suture anchor assembly is the spike or plug member which has on its first end a configuration which allows for easy puncturing of a soft tissue and on its second or other end a means for attachment of a suture material. The first end can be pointed or frustoconical in shape. The spike or plug can be ribbed, beaded, threaded or expandable on its exterior surface for secure mating with the interior wall section of the hollow anchoring sleeve. The suture material which is attached to the rear end of the spike or plug member has at least one loop portion positioned at its other end. The loop portion can be the same suture material as the suture

which is attached to the end of the spike or plug. Alternatively, the loop portion can be produced of a different material, other than suture, with different characteristics (i.e. - molded or metal) and can be attached to the spike or plug by a length of suture. In the alternative, the suture can be attached in one full loop on the rear end of the spike or plug member.

The spike or plug member, suture and loop portion can be all produced of the same material (i.e., molded). This would obviate need for the second end of the spike or plug member to have means for attachment of the suture thereto.

The spike or plug member is inserted during an open or endoscopic procedure, or the like, through the soft tissue and its piercing or pointed end is then threaded through the loop portion formed in the suture material prior to its ultimate insertion into the anchoring sleeve to facilitate a secure mating. Once the spike or plug member is threaded through the tissue and then through the loop portion and is inserted into the hollow anchoring sleeve, it is then securely attached through pressure by the surgeon into the sleeve. This attachment of the spike member to the hollow anchoring sleeve can be accomplished in one step or in a number of depth control steps (i.e., ratchets) to fine tune the tightness of the repair. This ratchet effect can be accomplished by a series of beads, ribs, thickening or the like on the exterior of the spike component. These would mate with the interior of the anchor sleeve. This allows for the tissue to be tightly attached to the bone mass. The unique device obviates the need for the surgeon to tie a knot with the suture material for reattachment of tissue to bone. Endoscopic procedures and some open surgical procedures are extremely difficult and must be completed in a very tight space. Obviation of the need of tying a knot is extremely beneficial and innovative.

Further, the unique knotless anchoring sleeve may be formed in one complete assembly. The hollow anchoring sleeve has one end for insertion into the bone mass and a suture material attached at its other end. The other end of the suture is attached to the rear end of the spike or plug member. This spike

or plug member can then be inserted directly through the tissue mass and into the hollow anchoring sleeve for attachment of soft tissue to bone. The length of the suture material is adjustable based upon the requirements of the surgical procedure. The procedure is a process wherein first the spike or plug member which may be ribbed, beaded, threaded or expandable is inserted through the soft tissue and then directly into the hollow anchoring sleeve. The hollow anchoring sleeve is then inserted into the bone mass. The soft tissue is thus secured to the bone mass. Tension is then adjusted by the depth of the anchor insertion and/or the ribbed, beaded, threaded or expandable mechanism for mating the spike member into the hollow anchoring sleeve.

In addition, it is within the contemplation of this invention to produce a knotless suture anchor assembly that includes a spike or plug member which can act as the bone anchor and spike without the necessity of a hollow anchoring sleeve. The spike or plug member, suture and loop portion is identical to that described above with the added feature of the spike or plug member having a bone anchoring means on its exterior surface.

As previously described, the suture and loop portion can vary in shape and be produced of the same or different materials.

Numerous other features of various embodiments of the knotless suture anchor assembly will be apparent from the following detailed description and the accompanying drawings.

BRIEF DESCRIPTION OF THE DRAWINGS

5 FIGS. 1a, 1b, 1c and 1d are perspective views of a hollow anchoring sleeve made in accordance with the present invention;

FIG. 2 is a perspective view of a spike member with suture element of the present invention;

10 FIG. 3 is a perspective view of an alternate embodiment of a spike member with suture element of the present invention;

15 FIG. 4 illustrates usage of the preferred embodiment of the present invention in conjunction with a bone mass and tissue during surgical reattachment;

20 FIG. 5 illustrates the preferred embodiment of the invention in place after attachment of tissue to bone mass has been completed;

FIG. 6 illustrates an alternate embodiment of the present knotless suture anchor assembly;

25 FIG. 7 illustrates the procedure for attachment of tissue to bone mass for the embodiment as outlined in FIG. 6;

FIG. 8 illustrates the embodiment of FIG. 6 showing tissue attached to bone;

30 FIG. 9 illustrates the spike components for an alternate embodiment of a knotless suture anchor assembly in accordance with the present invention;

35 FIG. 10 is a partial exploded view of the spike components and hollow anchoring sleeves inserted through soft tissue and mated together for attachment of tissue to bone mass;

FIG. 11 is an illustration of the embodiment of FIGS. 9 and 10 wherein tissue is attached to a bone mass in a secure manner;

5 FIG. 12 illustrates an alternate embodiment of the present invention;

10 FIG. 13 illustrates the embodiment of FIG. 12 in conjunction with a bone mass and tissue during surgical reattachment;

FIG. 14 illustrates an alternate embodiment of the present invention;

15 FIG. 15 illustrates the embodiment of FIG. 14 in conjunction with a bone mass and tissue during surgical reattachment;

20 FIG. 16 is an enlarged perspective view of a harpoon anchor;

FIG. 17 is an enlarged perspective view of an umbrella-like anchor;

25 FIG. 18 is an enlarged perspective view of a ribbed anchor;

FIG. 19 is an enlarged perspective view of a wedge-like anchor;

30 FIG. 20 is an enlarged perspective view of a threaded anchor;

35 FIG. 21 is an enlarged perspective view of a pronged anchor;

FIGS. 22a and 22b are perspective views of a spike member with suture element and stop means made in accordance with the present invention;

5 FIGS. 23a and 23b are perspective views of an alternate embodiment of a spike member with suture element of the present invention;

10 FIGS. 24a and 24b are perspective views of an alternate embodiment of a spike member with suture element of the present invention;

15 FIGS. 25a and 25b are perspective views of an alternate embodiment of a spike member with suture element of the present invention;

20 FIGS. 26a and 26b are perspective views of an alternate embodiment of a spike member with suture element of the present invention;

FIG. 27 illustrates the procedure for attachment of tissue to bone mass for the embodiment as outlined in FIG. 22b;

25 FIG. 28 illustrates the procedure for attachment of tissue to bone mass for the embodiment as outlined in FIG. 22a; and

30 FIG. 29 illustrates one procedure for attachment of tissue to bone mass for the embodiment as outlined in FIG. 23b.

DETAILED DESCRIPTION OF THE PRESENT INVENTION

Referring now to **FIG. 1**, the knotless suture anchor assembly of the present invention contains as one integral component a hollow anchoring sleeve for installation and attachment to a bone mass. The hollow anchoring sleeve **1**, as shown in **FIG. 1a**, is cylindrical in shape and possesses ribs or threads on its exterior. The device can also contain or be configured with prongs, umbrella spokes, have threads, be expandable, or have wedges, on its exterior, for secure attachment with the bone mass. These exterior attachment features are known to the industry.

FIG. 1b illustrates an alternate embodiment of the hollow anchoring sleeve **2** having a collar **3** to control depth of bone penetration. The collar prevents the sleeve from being forced too deep into the bone mass when the spike or plug member is inserted.

FIG. 1c illustrates an alternate embodiment of the hollow anchoring sleeve **4** wherein the sleeve has a pointed closed end **5** for ease of penetration into a bone mass.

FIG. 1d illustrates a hollow anchoring sleeve **7** with a collar **6** and a closed pointed end **8** as an alternate construction.

As pointed out in the Summary of the Invention, the hollow anchoring sleeve may also be shaped or configured with any means to secure said structure to a bone mass. The hollow anchoring sleeve may include a threaded exterior as disclosed in U.S. Patent No. 5,370,662. Further, the device may be expandable as disclosed in U.S. Patent No. 5,084,050. A configuration such as disclosed in U.S. Patent Nos. 5,037,422; 5,224,946; and 5,236,445 are also contemplated by the invention. Harpoon configurations such as disclosed by U.S. Patent Nos. 5,414,520 and 5,102,421 are also contemplated for the hollow anchoring sleeve.

It is also within the contemplation of the present invention to configure the anchoring sleeve in a harpoon-type

fashion such as disclosed by U.S. Patent Nos. 4,632,101 and 4,721,103 for secure anchoring within the bone mass. U.S. Patent Nos. 4,898,156; 5,207,679; 4,946,468; and 5,192,303 disclose anchoring mechanisms which can be utilized for the hollow sleeve member for installation within a bone mass. These patents fall within the contemplation of the present invention for methods or means for anchoring the sleeve to the bone mass. It is also within the contemplation of the present invent to configure this dowel-like hollow sleeve in any fashion to securely attach same to a bone mass.

The interior surface of the hollow anchoring sleeve is ribbed, beaded, threaded, expandable or smooth for secure engagement with said exterior surface of said spike member.

FIG. 2 shows a perspective view of the spike plug member with suture element embodying the present invention. Spike or plug member **12** is preferably cylindrical in shape with a sharp first end **14** and a second end **16** wherein the suture element **18** is attached. The suture element **18** has at its distal end a loop or ring **22**. The loop or ring portion **22** can be constructed of the same suture material as suture element **18** or it can be a separate molded material attached to the suture element **18** and loop portion **22** may be one molded component and attached to spike member **12** at end **16** or they may be all (spike, suture element and loop portion) one entire molded component. Further, the suture element **18**, alone, can be made from any type suture material which has been approved for surgical procedures for attachment of tissue to bone. The spike or plug member can form any shape so long as it mates with the hollow cylindrical sleeve as described above. The exterior of the spike or plug member **12** may be ribbed or threaded **24** as depicted in **FIG. 2** or may be beaded or expandable to allow for a secure tight fit with the inner hollow cylinder of the anchoring sleeve. Once inserted into a hollow anchoring sleeve, the exterior surface of the spike or plug member **12** engages the inner surface of the sleeve and can be ratcheted down to produce the desired tight fit. This ratcheting effect allows for fine tuning and tightening of the soft tissue to the bone during repair. The length of the suture

connection 18 is variable and may be adjusted prior to selection of a tool or during surgical procedure through any appropriate means. Likewise, the diameter of the loop 22 is adjustable and may be replaced by one long strip of suture-like material, or molded strip, 26 having a slot or hole 28 for insertion of the spike or plug member once it has been passed through a tissue for attachment.

FIG. 3 illustrates an alternate embodiment of the spike member with suturing material. The spike member 32 has attached at its rear end one complete loop of suture 34 which also has an adjustable diameter for various thicknesses of tissue reattachment.

Referring now to FIG. 4, there is illustrated a process for reattachment of tissue to bone mass. Bone mass 42 has a slot or hole 44 wherein a hollow anchoring sleeve 46 has been inserted. A tissue 48 has inserted therein a spike member 52 threaded through loop 54 for reattachment to the bone mass 42.

FIG. 5 depicts the knotless suture anchor assembly in place after the surgical procedure has been completed. Bone mass 62 has tissue 64 attached or reattached thereto.

The surgical procedure for reattaching or attaching tissue to bone mass includes first installation of the hollow anchoring sleeve 66. Secondly, the spike member 68 is inserted through the tissue 64 and then through at least one loop portion 72. The spike 68 with tissue 64 securely attached thereto is then secured directly into the anchoring sleeve 66 for attachment of tissue 64 to bone mass 62 completing the method.

Referring now to FIG. 6, there is disclosed an alternate embodiment of the knotless suture anchor system 82. There is disclosed a hollow anchoring sleeve 84 having attached thereto a spike or plug member 86 by a suture element 88. As discussed and described above in a preferred embodiment of the invention, the hollow anchoring sleeve 84 may take the shape or form of almost any type of anchor device. All the patents listed above are incorporated by reference. Configurations of the hollow anchoring sleeve having a collar, as well as a configuration incorporating any type of umbrella expansion means or

threading on the exterior or interior of the sleeve are contemplated as being part of the present invention. Further, the spike or plug member 86 is preferably threaded on its exterior with a pointed end for insertion through a tissue element. This may take the form of any structure and preferably has an exterior which is ribbed, beaded, threaded, smooth or expandable. Likewise, the suture element 88 may be made of any acceptable surgical suture material and in addition is lengthened based upon thickness and need requirements.

Referring now to FIG. 7, there is depicted the initial step in the process for attachment of tissue to bone utilizing the alternate embodiment of FIG. 6. A spike member 96 is inserted through a tissue 94 and into a hollow anchoring sleeve 98. The assembly is then attached to a bone mass 92.

Referring now to FIG. 8, there is disclosed the completed attachment or reattachment of tissue 102 to bone mass 104. The spike or plug member 106 is inserted through said tissue 102 and then inserted into hollow anchoring sleeve 108 for complete attachment to bone mass 104 at a previously drilled section 110. This enables one to surgically reattach the tissue 102 to bone mass 104 in a virtual one step process.

Additionally, the process embodied by FIG. 8 may be undertaken in two steps. First, the spike member 106 is inserted through the soft tissue 102 and into the hollow anchoring sleeve 108.

Secondly, the entire assembly 112, spike member 106 which has been inserted into the sleeve 108, is inserted into the bone mass 104. Regardless of the process used, the repair tightness is adjusted by the depth of anchor insertion into bone and/or the ratcheting effect of the spike in the anchor sleeve.

FIG. 9 depicts an alternate preferred embodiment. First and second spike or plug assembly members, 120 and 130, respectively, are depicted for the knotless suture anchor assembly. There is disclosed first spike or plug assembly member 120 having spike means 121 for insertion into a hollow anchoring sleeve as depicted in FIGS. 1a - 1d. Spike or plug member 121 is preferably threaded with a pointed end for insertion through

a tissue element and secure fixation with said hollow anchoring sleeve. The spike or plug member may take the form of any structure and preferably has an exterior which is ribbed, threaded, beaded, expandable or smooth. The diameter of thickness of the member is preferably equal to or incrementally less than the entire diameter of the hollow anchoring sleeve for a secure fit. In situations where ribs, threads, beads, or the like, are utilized on the spike member, the diameter of the member with protrusions may initially exceed the inner diameters of the hollow anchoring sleeve and would deform upon insertion.

The rear end 122 of the spike member 121 has attached or tied thereto a suture element 123. The suture element 123 has attached or molded therewith a catch device, such as a ring element, 124 which is preferably rigid. The spike member 121, suture element 123 and catch device (ring element) 124 may be made of separate materials or molded together as one piece. In addition, the spike member 121 and suture element 123 may be molded as one element or the suture element 123 and catch device (ring element) 124 may be molded as one element.

Second spike assembly member 130 includes a spike or plug member 131 for insertion into a hollow anchoring sleeve as depicted in FIGS. 1a - 1d. The element 131 is described above and can be the same or different as spike element 121. To the rear end 132 of the spike member 131 there is tied or attached a suture element 133. The suture element 133 has attached or molded therewith a spherical, or the like, stop means 134.

As stated above, the three components, spike member 131, suture element 133 and stop means 134 can be combined as separate components or molded together as one entire component or a combination of two components.

Referring now to FIG. 10, first spike assembly member 120 is inserted into tissue 140. The spike member 121 can be inserted into a hollow anchoring sleeve 142 either before or after the hollow anchoring sleeve 142 is inserted into bone mass 150. Spike member 131, of spike member assembly means 130, is inserted through catch device (ring element) 124, of spike member assembly 120. The spike member 131 is then inserted through

tissue 140 and then into hollow anchoring sleeve 144, or directly into hollow anchoring sleeve 144. The hollow anchoring sleeve 144 can be anchored to bone mass 150 before or after spike member 131 has been inserted therein. The stop means 134 mates with catch device (ring element) 124 dragging the tissue into a secure fit with bone mass 150 (See FIG. 11.)

Once the spike members have been inserted into the hollow anchoring sleeves they can be ratcheted down to a desired depth to adjust the tightness of the soft tissue repair to bone mass. Tightness can also be adjusted by the depth of anchor sleeve insertion into the bone mass.

Stop means 134 may be spherical with a diameter greater than catch device (ring element) 124, or may be any shape which would facilitate a mating with the catch device. Likewise, the catch device need not be circular, but requires only an opening to allow passage of a spike member and prevent passage of the stop means. The catch device 124, depicted in FIGS. 10 and 11, can take the form of a ring, square, slot, or any shape that will cooperate and hold stop means 134 from being pulled therethrough.

Knotless suture anchor assembly 150 is an alternate embodiment of the present invention (FIG. 12). The assembly 150 includes a spike/anchor means 152, a suture element 154, and a loop portion 156. As discussed above, the suture element 154 and loop portion 156 may be made of the same or different materials. In addition, the spike/anchor means 152 can be molded with the suture element 154 and loop portion 156 as one piece or as separate components, as desired. The spike/anchor means can be configured, as desired, to securely attach the assembly 150 to a bone mass. The spike/anchor means may include all the attachment means as described above for the hollow anchoring sleeve such as harpoon type means 158, prongs, umbrella spokes, threads, wedges or the like.

Additionally, the entire suture element 154 may be configured in a complete loop as depicted in FIG. 3, or may merely have a slit along its length as depicted in FIG. 2.

When performing a procedure, loop portion 156 is pulled through soft tissue 160. Once the loop portion 156 has been

pulled through the soft tissue 160, the spike/anchor means 152 is inserted through the loop portion 156 and directly into bone mass 170 for attachment of tissue 160 to bone mass 170. The length of suture 154 and depth of insertion of the spike/anchor means 152 controls the secure tightness of repair of tissue 160 to bone mass 170, and is adjusted as desired.

FIG. 14 depicts an embodiment of the present invention wherein a first knotless suture anchor assembly 180 is provided as described in accordance with knotless suture anchor assembly 150, as depicted in FIG. 12 and previously described. A second knotless suture anchor assembly 185 is also provided to being used in conjunction with assembly 180 to perform a surgical attachment of tissue to bone.

First the catch device 181 is inserted through soft tissue 190 from the underside of the tissue first (see FIG. 15). Then a spike/anchor means 182 of assembly 180 is inserted into the bone mass 192. Next, a spike/anchor means 186 (with bone anchoring features) is threaded through catch device 181 and inserted into bone mass 192. Stop means 187 mates with catch device 181 and the sutures 183 and 188 are pulled taught to securely attach soft tissue 190 to bone mass 192.

FIG. 22, including 22a and 22b, shows a perspective view of the spike plug member with suture element and stop means, of the two-piece and one-piece embodiment, respectively, embodying the present invention. Spike or plug member 212 is preferably cylindrical in shape with a sharp first end 214 and a second end 216 wherein the suture element 218 is attached. The suture element 218 has at its distal end a disc-like stop means 222. The stop means 222 can be constructed of any material may be one molded component and attached to spike member 212 at end 216. Further, the suture element 218, alone, can be made from any type suture material which has been approved for surgical procedures or a molded material for attachment of tissue to bone. The spike or plug member can form any shape so long as it mates with the hollow cylindrical sleeve as described above. The exterior of the spike or plug member 212 may be ribbed or threaded 224 as depicted in FIG. 22 or may be beaded or expand-

able to allow for a secure tight fit with the inner hollow cylinder of the anchoring sleeve. Once inserted into a hollow anchoring sleeve, the exterior surface of the spike or plug member 212 engages the inner surface of the sleeve and can be ratcheted down to produce the desired tight fit. The interface of the spike and sleeve allows for movement of the spike in only one direction and resists pullout or movement out of the sleeve. This ratcheting effect allows for fine tuning and tightening of the soft tissue to the bone during repair. The length of the suture connection 218 is variable and may be adjusted prior to selection of a tool or during surgical procedure through any appropriate means. Likewise, the diameter of the disc-like stop means 222 is adjustable. FIG. 22b is identical to 22a but for anchoring means 226 attached to the spike or plug member 228. This one-piece embodiment allows for tissue reattachment without an anchoring sleeve. The spike or plug member anchors directly into the bone mass.

FIG. 23 illustrates an alternate embodiment of the spike member with suturing material and stop means. In FIG. 23a, the spike member 232 has attached at its rear a suture 234 and rod-like stop means 236. This is the embodiment of the one-piece anchor. FIG. 23b illustrates the spike or plug member of the two-piece embodiment when used in combination with an anchoring sleeve.

FIG. 24 illustrates an alternate embodiment of the spike member with suturing material and stop means. In FIG. 24a, the two-piece embodiment, Spike member 240 has attached thereto at least one suture means 242 connected to a stop means 244 configured in the shape of a ring or hoop. FIG. 24b illustrates the one-piece embodiment wherein anchoring means 246 is attached to the spike or plug member 248 for attachment to bone without an anchoring sleeve.

FIG. 25 contains alternate embodiments 25a and 25b. FIG. 25a, the two-piece embodiment, includes a spike means 250, a suture means 252 attached thereto, and an X-like stop means 254. FIG. 25b, the one-piece embodiment, illustrates an embodiment of the configuration wherein anchoring means 256 is attached

to the spike or plug means 258 for attachment to bone when an anchoring sleeve is not utilized.

FIG. 26 contains FIGS. 26a and 26b which are alternate embodiments of the invention including a spike member 260, suturing means 262 attached thereto, and a stop means 264 configured in a horseshoe configuration. FIG. 26b illustrates an alternate embodiment of the horseshoe configuration wherein the spike or plug member 266 has anchoring means 268 attached thereon for direct attachment to bone without the utilization of an anchoring sleeve.

Referring now to FIG. 27 and FIG. 28, there is illustrated a surgical procedure for reattaching or attaching tissue to bone depicting the spike or plug embodiments illustrated in FIG. 22. The procedure can be enacted for any of the embodiments outlined in FIGS. 22, 23, 24, 25 and 26. FIG. 27 illustrates the procedure wherein an anchoring sleeve is not utilized. Spike or plug means 270 having anchoring means 272 is inserted through tissue 274 and directly into bone 276. The stop means 278 grabs the tissue 274 and pulls same back into reattachment or attachment with bone 276 when the spike or plug member is forced into the opening in the bone. The tightness of the repair is adjusted by the length of suture 270 and/or the depth of the insertion of spike member 272 into the bone mass.

FIG. 28 depicts a procedure wherein an anchoring sleeve 280 is first inserted into bone mass 282. Subsequent to the insertion of the anchoring sleeve 280, a spike or plug member 286 is inserted through tissue 284 and into the anchoring sleeve 280. The spike or plug member 286 is then ratcheted down into the anchoring sleeve 280 to pull tissue mass 284 into direct and secure mating with bone mass 282.

Referring now to FIG. 29, there is an alternate surgical procedure disclosed for utilization of the rod-like stop means depicted in FIG. 23. Initially the rod-like stop means 290 is inserted through tissue mass 292. Once the rod-like stop means rests on top of the tissue mass, the spike or plug member 294 is then inserted into a previously inserted anchoring sleeve 296. The spike or plug member 294 is then ratcheted down into

the anchoring sleeve for secure mating or attachment of the tissue 292 to the bone mass 300. This procedure may also be undertaken with the one-piece anchor having a spike or plug means as depicted in FIG. 23a which omits the initial insertion of an anchoring sleeve.

In addition to the shapes illustrated for the stop or catch means portion of the invention, the stop means can be any planar or non-planar shape such as, but not limited to, C-shaped, planar with one or more openings, bar-shaped, curved or non-planar bar-shaped. Further the stop means is attached to the spike or plug member by one or more suture elements. The suture element or connection can be made up of a known suture material such as Ethibond® or Prolene®, or it can be made of polymer materials such as ultrahigh molecular weight polyethylene. The connection or suture element can be formed of bio-absorbable material such as a polylactide polymer. Additionally, the suture element can be part of the stop means and formed by a molding process or the like.

The suture element can be connected to the stop means and an anchor in a variety of ways such as fusion or molding or by mechanical means such as glue, a weld or by mere tying.

In many situations throughout the discussion above, the terminology secure attachment of soft tissue to bone has been used. Such terminology refers to the attachment or reattachment of tissue to bone through the insertion of a spike member into a hollow anchoring sleeve or a spike/anchor means into a bone mass. In the former situation, the spike member can seat into the sleeve in a one step mating procedure or be inserted and ratcheted down in a step wise fashion into the sleeve. Either situation will function effectively and selection is based upon the instant facts of the surgical procedure. Further, the sleeve itself may be seated in the bone mass at varying depths. Again, such depth is a selection based upon the facts of the instant procedure. In the latter situation, where a spike/anchor means is used, depth of insertion of the device into the bone is a selection or choice of the surgeon during the procedure. In all situations, the spike member or spike/anchor means is designed

not to back up or exit once mated with the sleeve, ratcheted down into the sleeve, or inserted into the bone mass to avoid and prevent withdrawal therefrom.

5 It is also within the contemplation of the invention to make the spike or plug member for direct insertion into the bone with screws, prongs, spikes, a wedge means or any means wherein the spike or plug member anchors securely into the bone mass facilitating attachment or reattachment of tissue to skin.

10 Further, the spike or plug member or a portion of the spike or plug member may be made with bioabsorbable material.

15 While a preferred embodiment of the invention in a knotless suture anchor system has been shown and described herein, it should be understood that the present disclosure is made by way of example only and that variations to the structure shown and its use are possible within the scope of this disclosure without departing from the subject matter coming within the scope of the following claims, and a reasonable equivalency thereof, which claims we regard as our invention.

**THE EMBODIMENTS OF THE INVENTION IN WHICH AN EXCLUSIVE
PROPERTY OR PRIVILEGE IS CLAIMED ARE DEFINED AS FOLLOWS:**

1. A knotless suture anchor assembly for attachment of tissue to a bone mass, said assembly comprising:

a) at most one anchor member having a first end and a second end, said first end of said anchor member having a suture element attached thereto, wherein said suture element has at least one loop portion located along its length, said anchor member to be passed through said at least one loop portion of said suture element; and

b) at most one hollow anchoring sleeve having bone attachment means located on said hollow anchoring sleeve for securely anchoring said sleeve to said bone mass for receiving said anchor member thereby securely attaching said tissue to said bone mass.

2. A knotless suture anchor assembly claimed in claim 1, wherein said anchor member has an exterior surface which is smooth, ribbed, threaded, beaded or expandable, for secure engagement of said anchor member with said hollow anchoring sleeve.

3. A knotless suture anchor assembly as claimed in claim 1, wherein said hollow anchoring sleeve has an exterior surface which is ribbed, threaded, pronged, or smooth for secure engagement of said sleeve with said bone mass.

4. A knotless suture anchor assembly as claimed in claim 1, where said hollow anchoring sleeve has an interior surface which is threaded, beaded or smooth for secure engagement of said anchor member.

5. A knotless suture anchor assembly as claimed in claim 1, wherein said suture element has a first and a second end which are both attached to said anchor member at said first end of said anchor member.

6. A knotless suture anchor assembly as claimed in claim 1, wherein said hollow anchoring sleeve has a first end and a second end and a collar attached to said first end for flush engagement of said hollow anchoring sleeve with said bone mass when inserted into said bone mass when inserted into said bone mass.

7. A knotless suture anchor assembly for the attachment of tissue to a bone mass, comprising:

a) an anchor member having a first end and a second end, for insertion through said tissue;

b) a hollow anchoring sleeve, having a first end and a second end, for installation and attachment to a bone mass for receiving said anchor member which has been inserted through said tissue; and

c) a suture element having a first end, and a second end, wherein said first end of said suture element is attached to said second end of said anchor member and said second end of said suture element is attached to said second end of said hollow anchoring sleeve.

8. A knotless suture anchor assembly as claimed in claim 7, wherein said anchor member has an exterior surface which is ribbed, threaded, beaded or expandable, for secure engagement of said anchor member with said hollow anchoring sleeve.

9. A knotless suture anchor assembly as claimed in claim 7, wherein said hollow anchoring sleeve has an exterior surface which is ribbed, threaded, smooth or pronglike, for secure engagement of said sleeve with said bone mass.

10. A knotless suture anchor assembly as claimed in claim 7, wherein said hollow anchoring sleeve has an interior surface which is ribbed, threaded, or smooth for secure engagement of said anchor member.

-23-

11. A knotless suture anchor assembly as claimed in claim 7, wherein said hollow anchoring sleeve has a first end and a second end and a collar attached to said first end for flush engagement for said hollow anchoring sleeve with said bone mass.

12. A knotless suture anchor assembly comprising:

a) a first anchor member assembly comprising a first anchor member having a first end and a second end, said first end of said first anchor member having a suture element attached thereto, wherein said suture element has a catch device located along its length;

b) a second anchor member assembly comprising a second anchor member having a first end and a second end, said first end of said second anchor member having a suture element attached thereto, wherein said suture element has a stop means located along its length, wherein said second anchor member is passed through said at least one catch device of said first anchor member assembly until said stop means engages said catch device; and

c) two hollow anchoring sleeves for installation and anchoring to a bone mass for receiving said first and second anchor members after said second anchor element has been passed through said catch device of said first anchor assembly member.

13. A knotless suture anchor assembly as claimed in claim 12, wherein said first and second anchor members have exterior surfaces which are smooth, ribbed, threaded, beaded or expandable, for secure engagement of said anchor members with said hollow anchoring sleeves.

14. A knotless suture anchor assembly as claimed in claim 12, wherein said two hollow anchoring sleeves have exterior surfaces which are ribbed, threaded, pronged, or smooth, for secure engagement of said sleeves with said bone mass.

15. A knotless suture anchor assembly as claimed in claim 12, wherein said two hollow anchoring sleeves have interior surfaces which are ribbed, threaded, or smooth for secure engagement of said anchor members.

16. A knotless suture anchor assembly as claimed in claim 12, wherein two hollow anchoring sleeves have a first end and a second end and a collar attached to said first end for flush engagement of said hollow anchoring sleeve with said bone mass.

17. A knotless suture anchor assembly for attachment of tissue to a bone mass, said assembly comprising:

an anchor means for attachment to said bone mass, said anchor means having a first end and a second end, said first end having a suture element attached thereto, wherein said suture element has at least one loop portion located along its length for passing through said soft tissue, said second end of said anchor having a bone attachment means located on said suture anchor for securely anchoring said anchor to bone and means being passed through said loop portion of said suture element and being anchorable into said bone mass for secure attachment of said tissue to said bone mass.

18. A knotless suture anchor assembly as claimed in claim 17, wherein said anchor means for attachment to said bone mass is a harpoon anchor, a wedge-like anchor, an umbrella-like anchor, a ribbed anchor, a threaded anchor, or a pronged anchor.

19. A knotless suture anchor assembly as claimed in claim 17, wherein said suture element has a first and a second end which are both attached to said anchor means at said first end of said anchor means.

20. A knotless suture anchor assembly for attachment of tissue to a bone mass, comprising:

a first knotless suture anchor assembly comprising a first anchor means for attachment to said bone mass, said first anchor means having a first end and a second end, said first

-25-

end having a suture element attached thereto, wherein said suture element has a catch means located along its length for passing through said soft tissue, and

a second knotless suture anchor assembly comprising a second anchor means for attachment to said bone mass, said second anchor means having a first end and a second end, said first end of said second anchor means having a suture element attached thereon, wherein said suture element has a stop element located along its end for engagement with said catch device of said first knotless suture anchor assembly, wherein said second end of said second anchor means is for passing through said catch means of said first knotless suture anchor assembly and for insertion into said bone mass for secure attachment of said tissue to said bone mass.

21. A knotless suture anchor assembly as claimed in claim 20, wherein said first and second anchor means for attachment to said bone mass are harpoon anchors, wedge-like anchors, umbrella-like anchors, ribbed anchors, threaded anchors, or pronged anchors.

22. A knotless suture anchor assembly as claimed in claim 20, wherein said catch means of said first knotless suture anchor assembly has a circular shape, a slotted shape, a square shape, or a triangular shape, with an opening smaller than a size of said stop element of said second knotless suture anchor assembly.

23. A knotless suture anchor assembly for attachment of tissue to bone, said assembly comprising:

- a) a spike member having a first end and a second end;
- b) at least one suture element having a first end and a second end wherein said first end of said at least one suture element is connected to said second end of said spike member;
- c) a stop means connected to said second end of said suture element; and
- d) a hollow anchoring sleeve for installation and attachment to a bone mass for receiving and having a length

-26-

sufficient to completely encircle said first end and said second end of said spike member.

24. A knotless suture anchor assembly as claimed in claim 23, wherein said spike member has an exterior surface which is smooth, ribbed, threaded, or expandable for secure engagement of said spike member with said hollow anchoring sleeve.

25. A knotless suture anchor assembly as claimed in claim 23, wherein said hollow anchoring sleeve has an exterior surface which is ribbed, threaded, or smooth for secure engagement of said sleeve with said bone mass.

26. A knotless suture anchor assembly as claimed in claim 23, wherein said hollow anchoring sleeve has an interior surface which is ribbed, threaded, or smooth for secure engagement of said spike member.

27. A knotless suture anchor assembly as claimed in claim 23, wherein said stop means is disc-shaped, rod-shaped, ring-shaped, x-shaped, or horseshoe-shaped.

28. A knotless suture anchor assembly as claimed in claim 23, wherein said hollow anchoring sleeve has a first end and a second end and a collar attached to said first end for secure engagement of said hollow anchoring sleeve with said bone mass.

29. A knotless suture anchor assembly for attachment of tissue to bone, said assembly comprising:

- a) a spike member having a first end and a second end;
- b) at least one suture element having a first end and a second end wherein said first end of said suture element is connected to said second end of said spike member;
- c) a stop mean having a surface for securing said tissue and being permanently attached to said second end of said suture element; and
- d) an anchor means connected to said first end of said

-27-

spike member for installation and attachment of said spike member to said bone mass.

30. A knotless suture anchor assembly as claimed in claim 30, wherein said stop means is disc-shaped, rod-shaped, ring-shaped, X-shaped, or horseshoe-shaped.

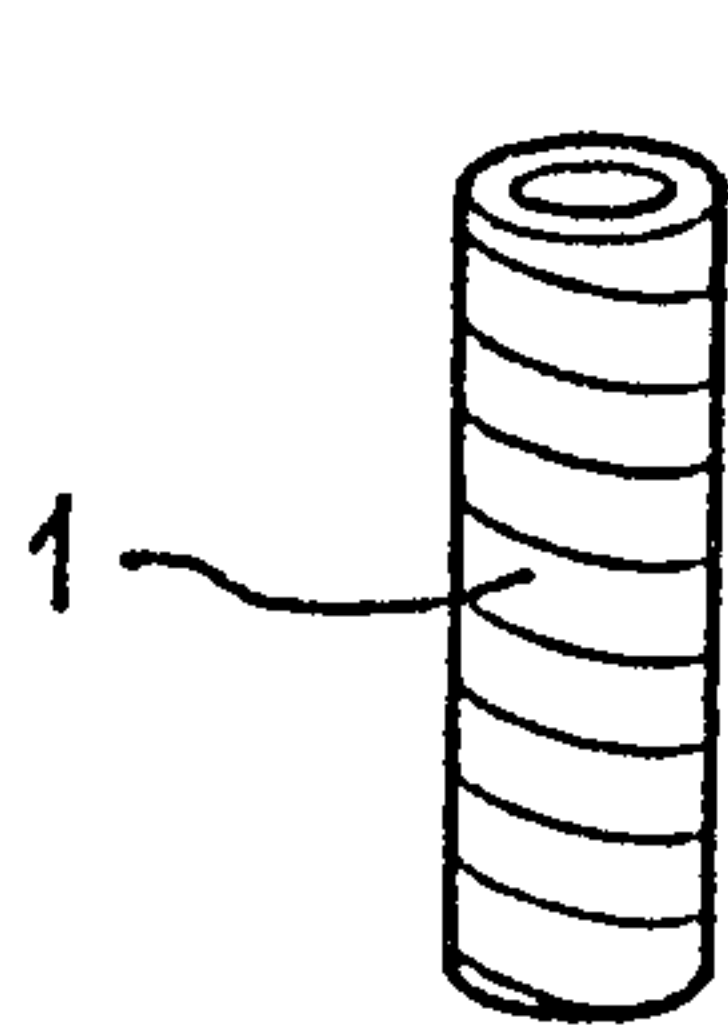

FIG. 1a

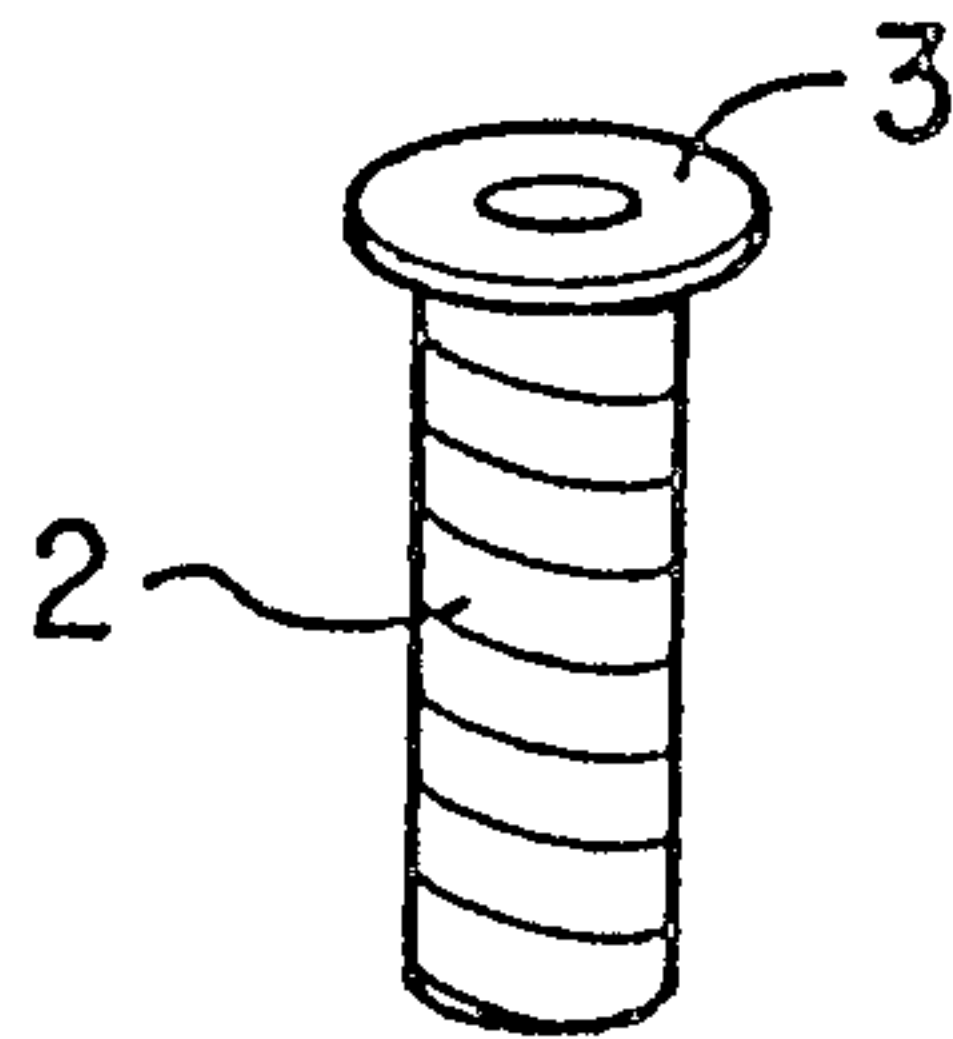

FIG. 1b

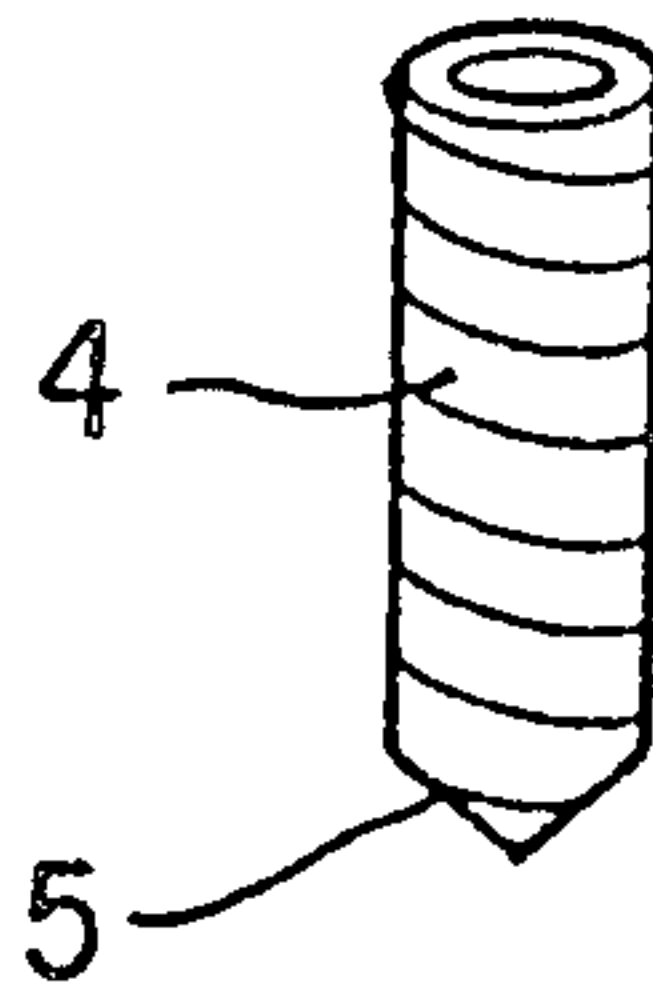

FIG. 1c

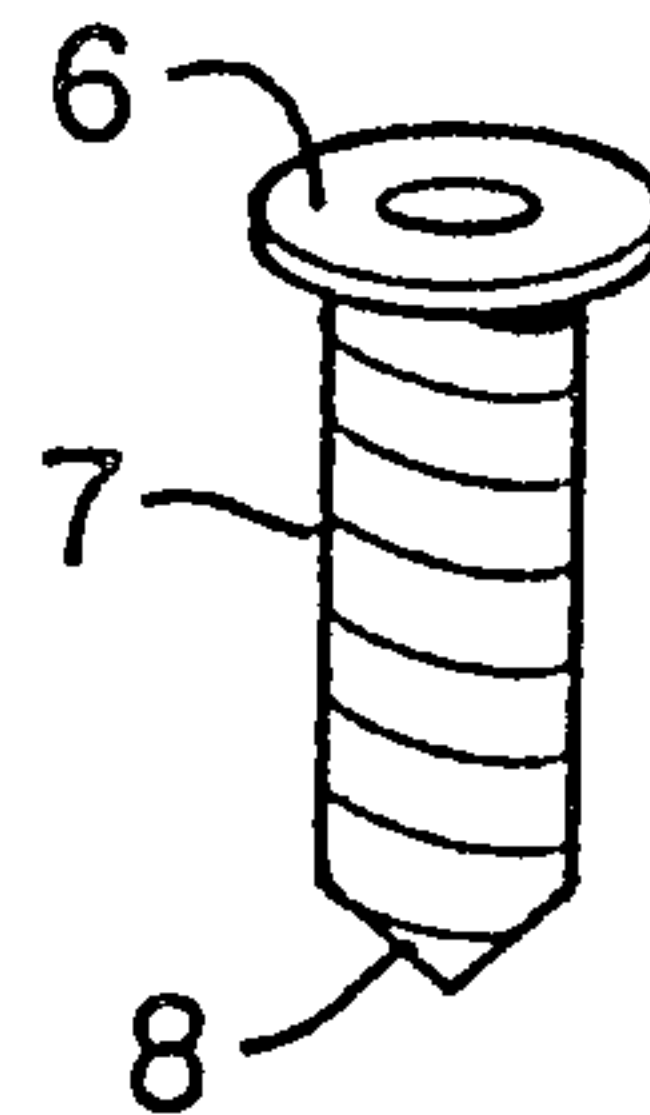

FIG. 1d

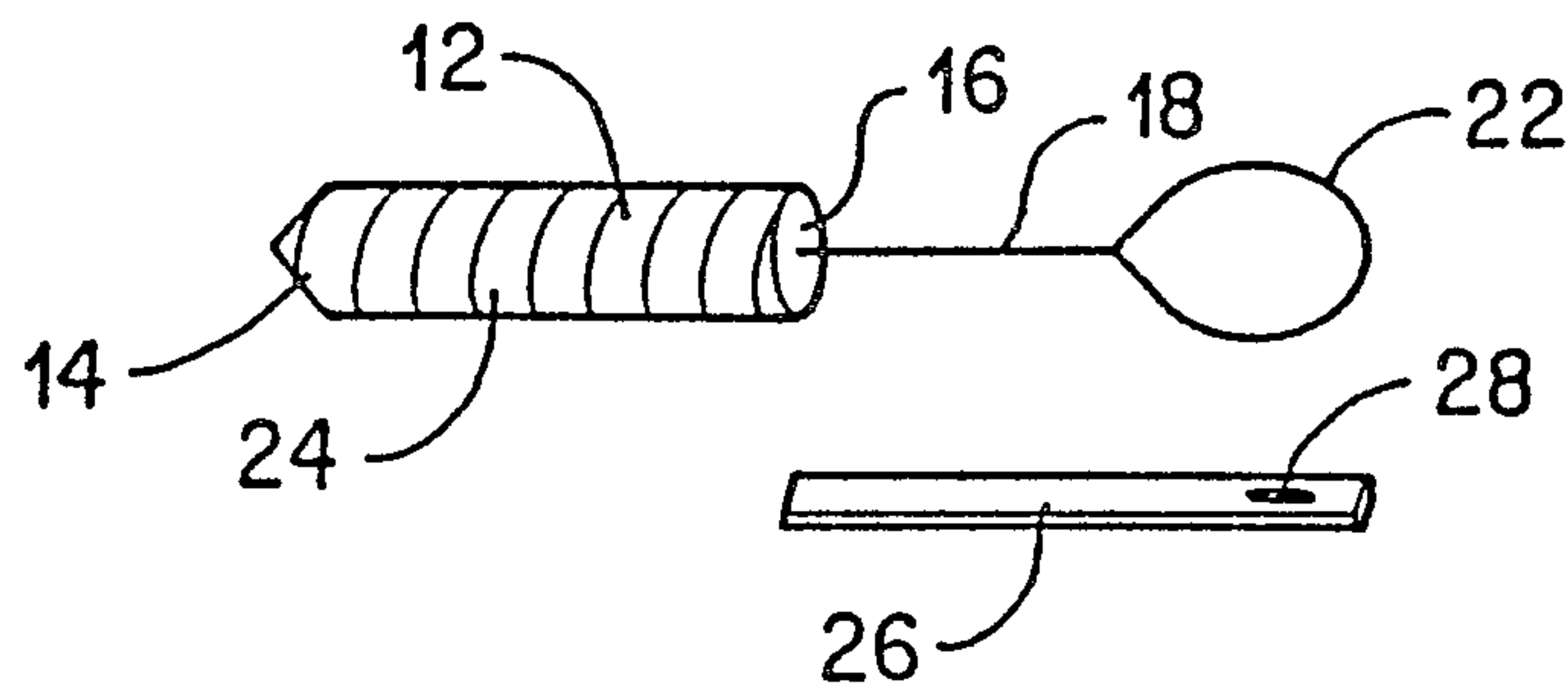

FIG. 2

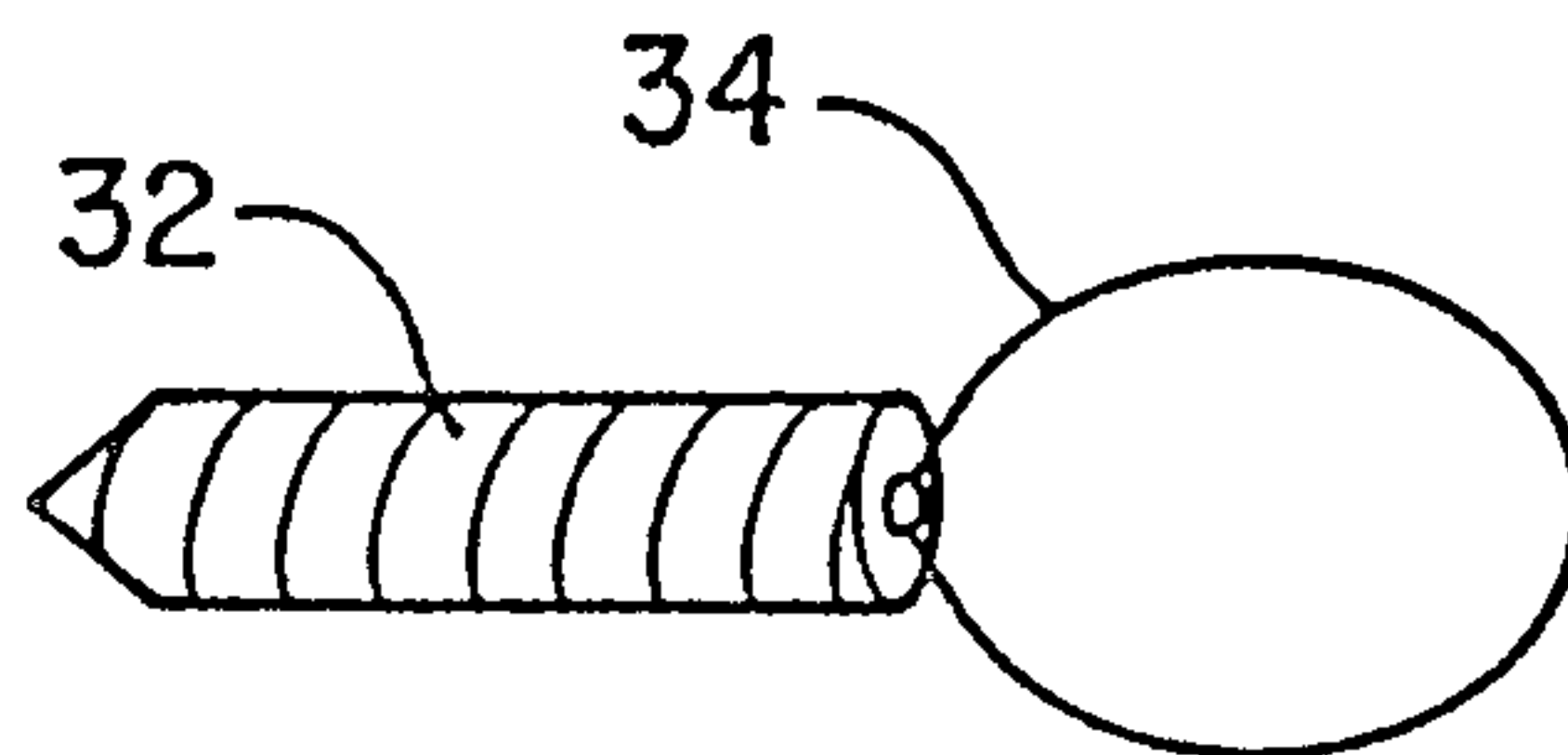

FIG. 3

2 / 11

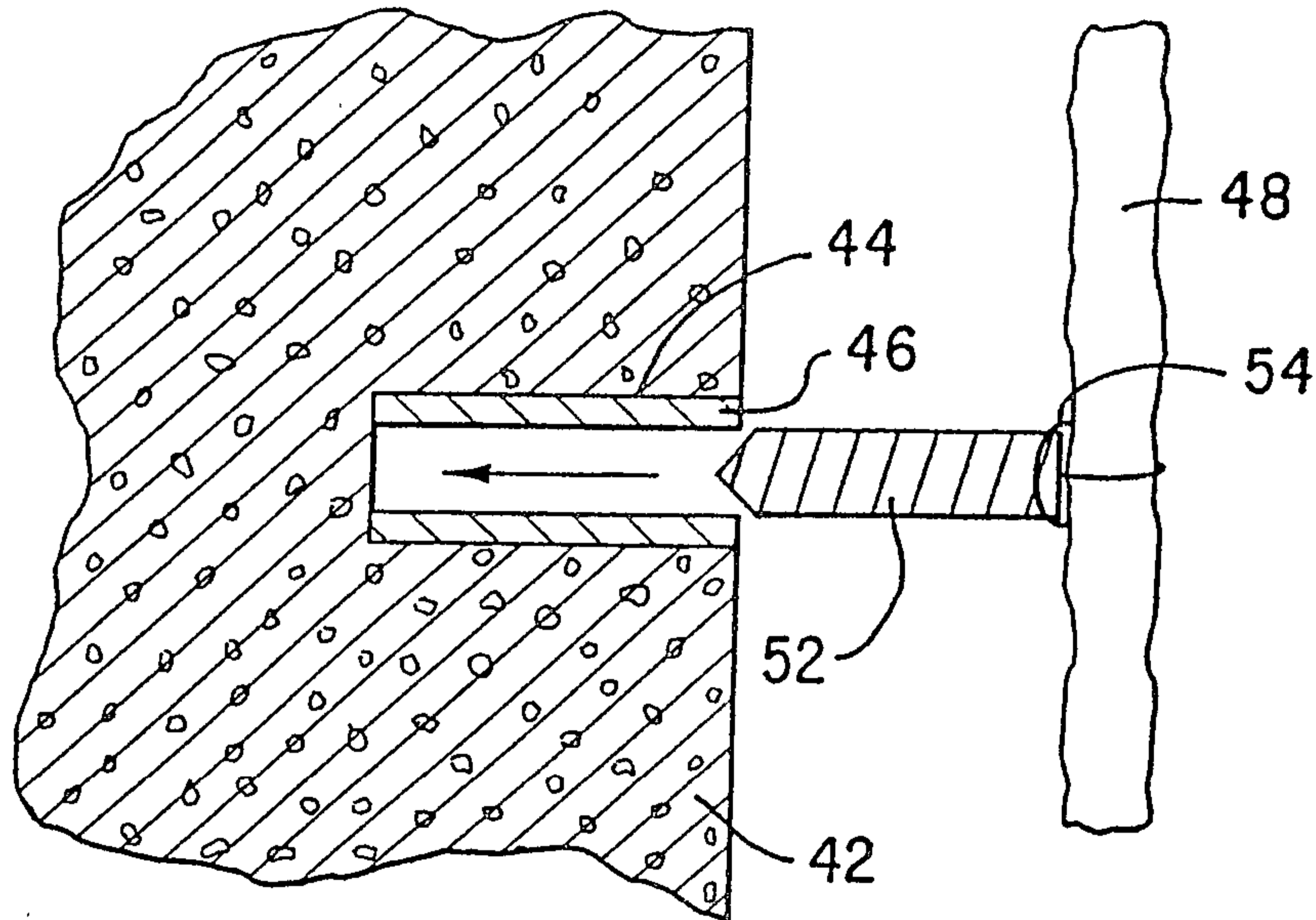

FIG. 4

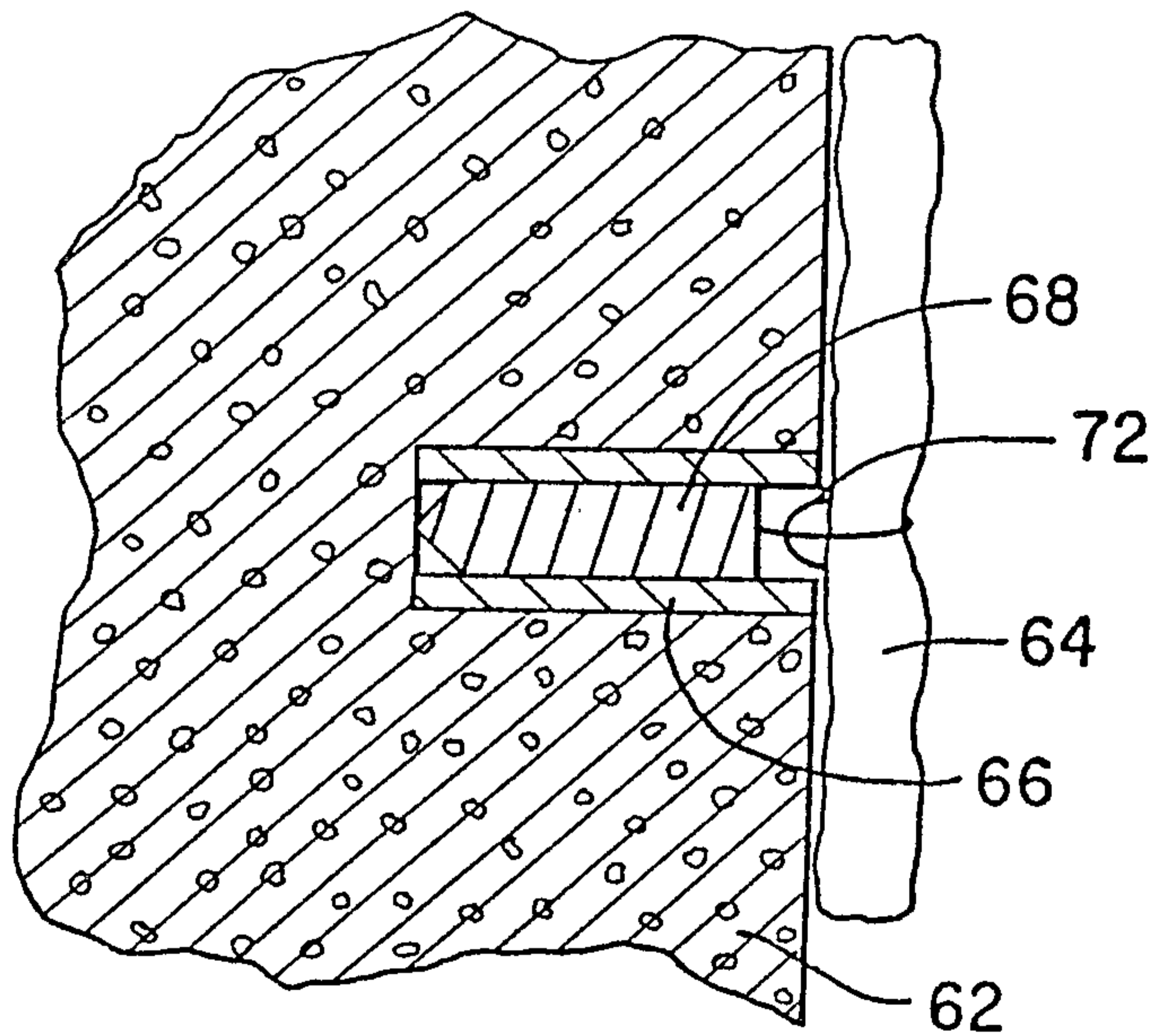

FIG. 5

3/11

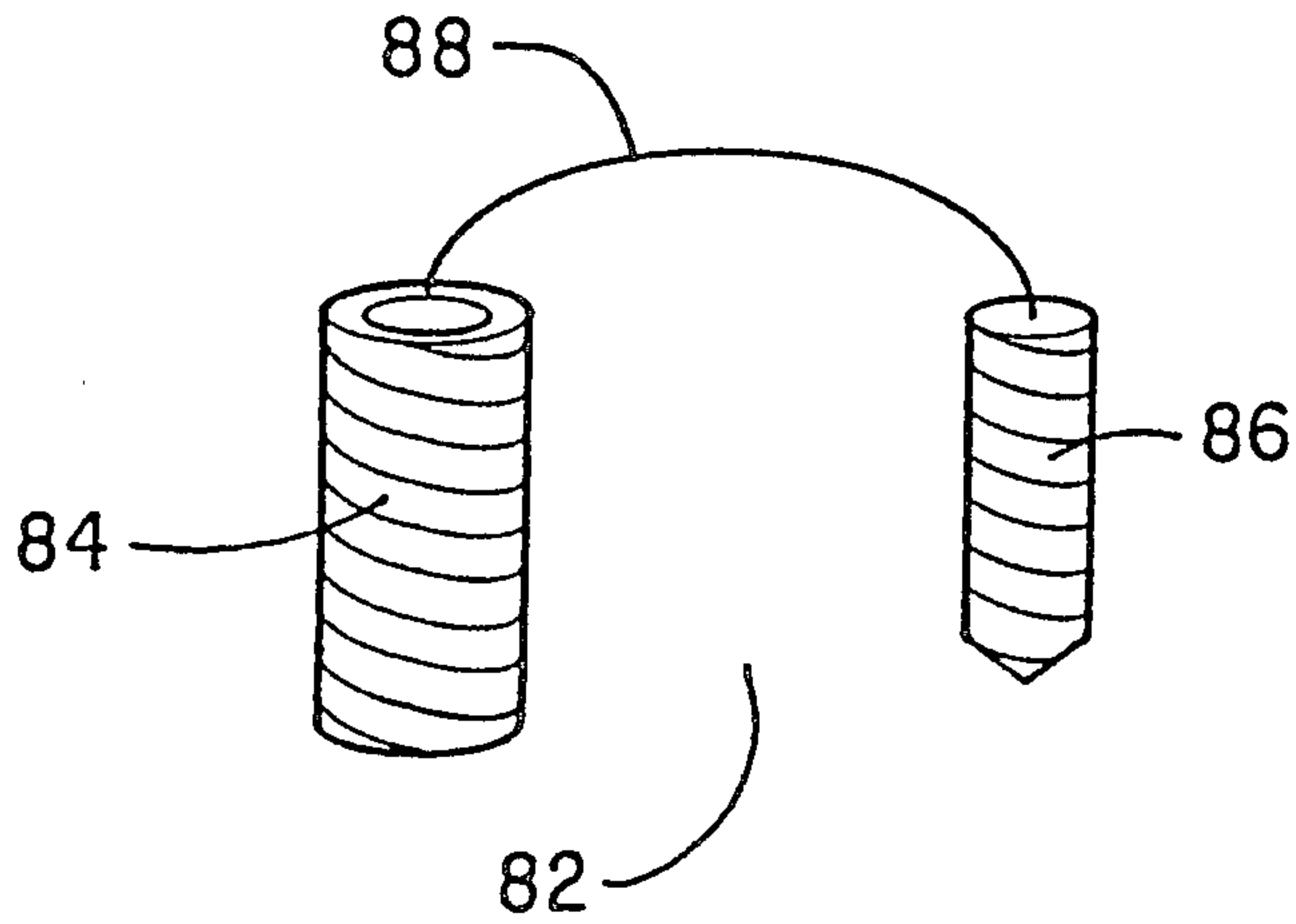

FIG. 6

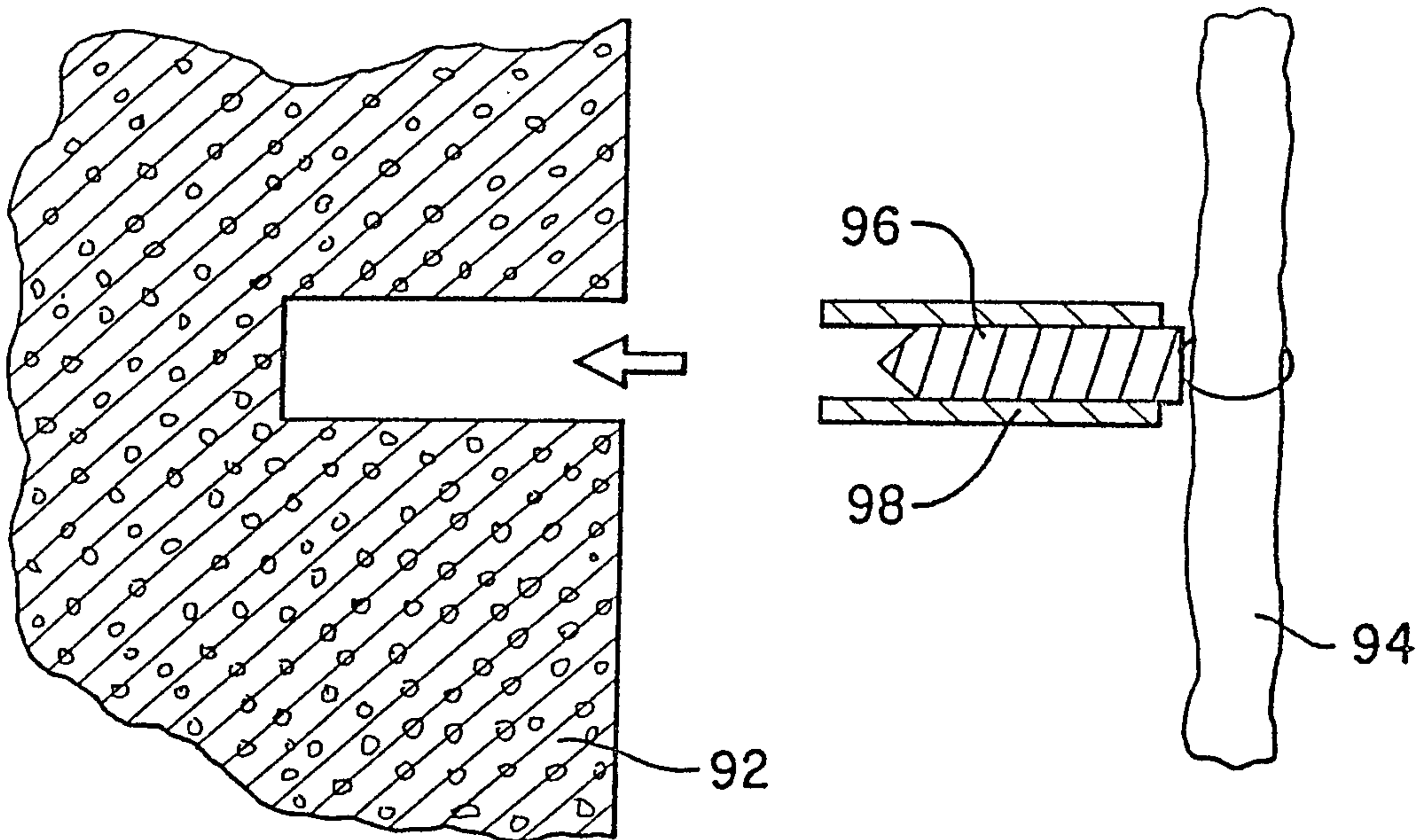

FIG. 7

4/11

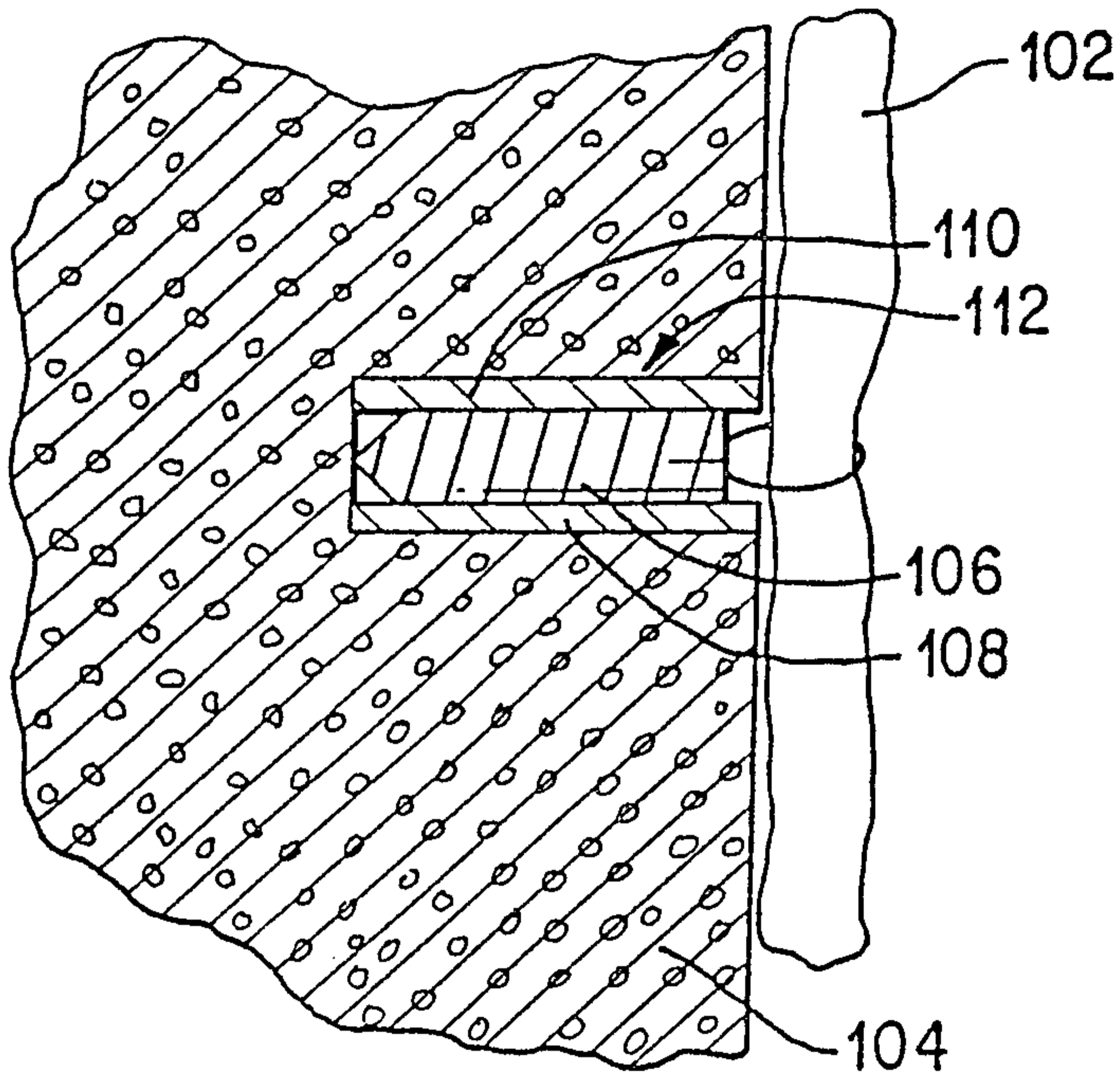

FIG. 8

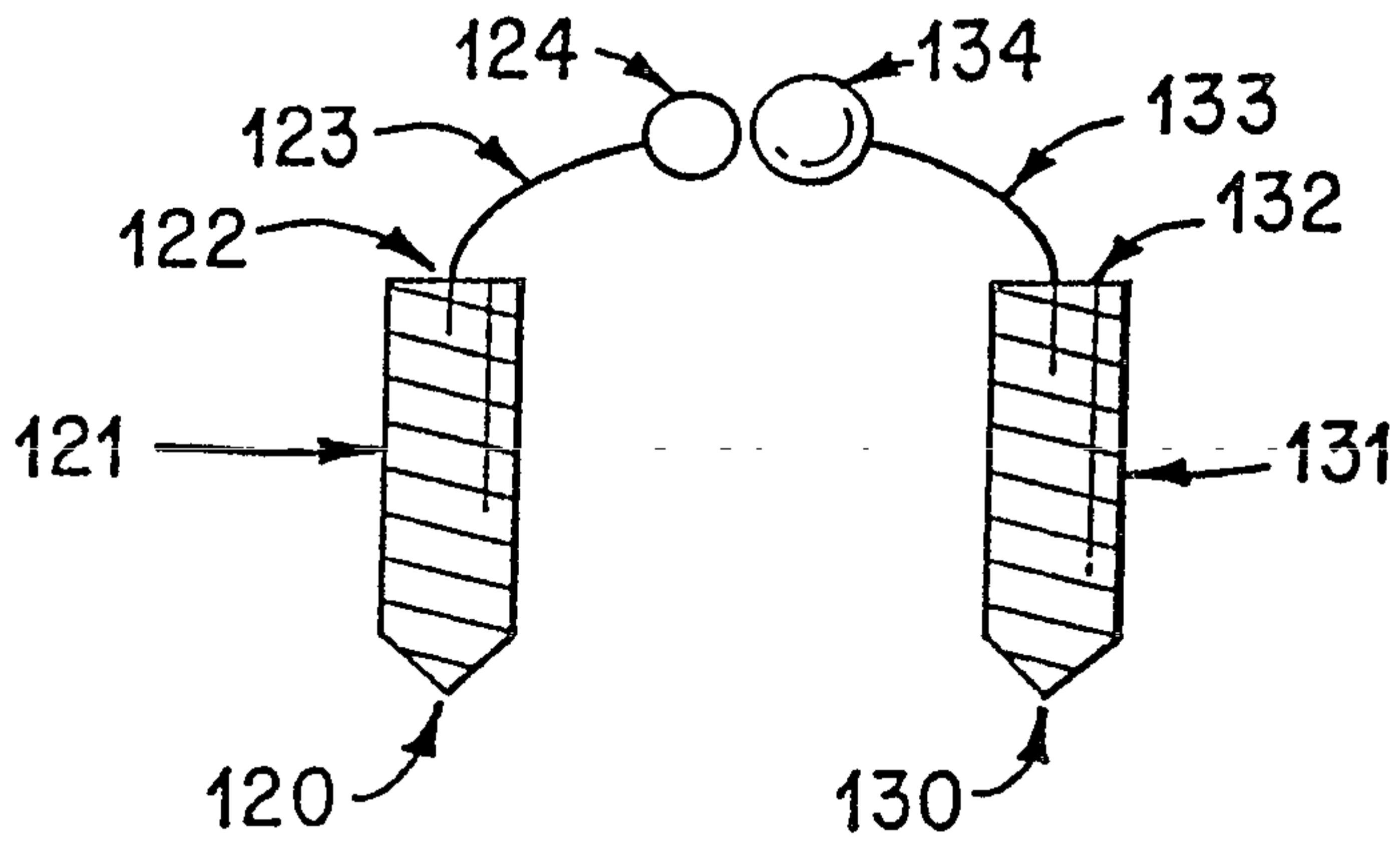

FIG. 9

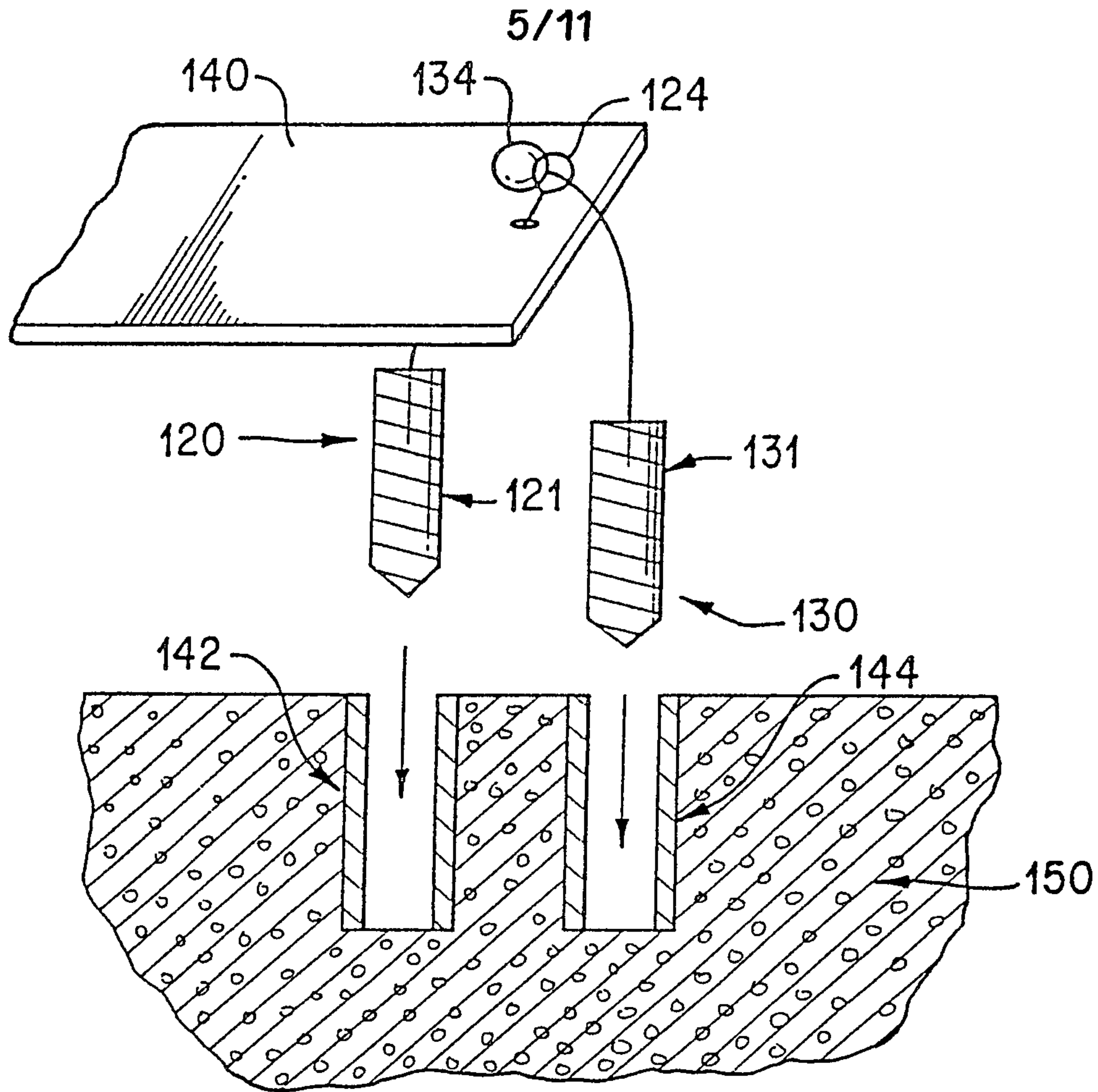

FIG. 10

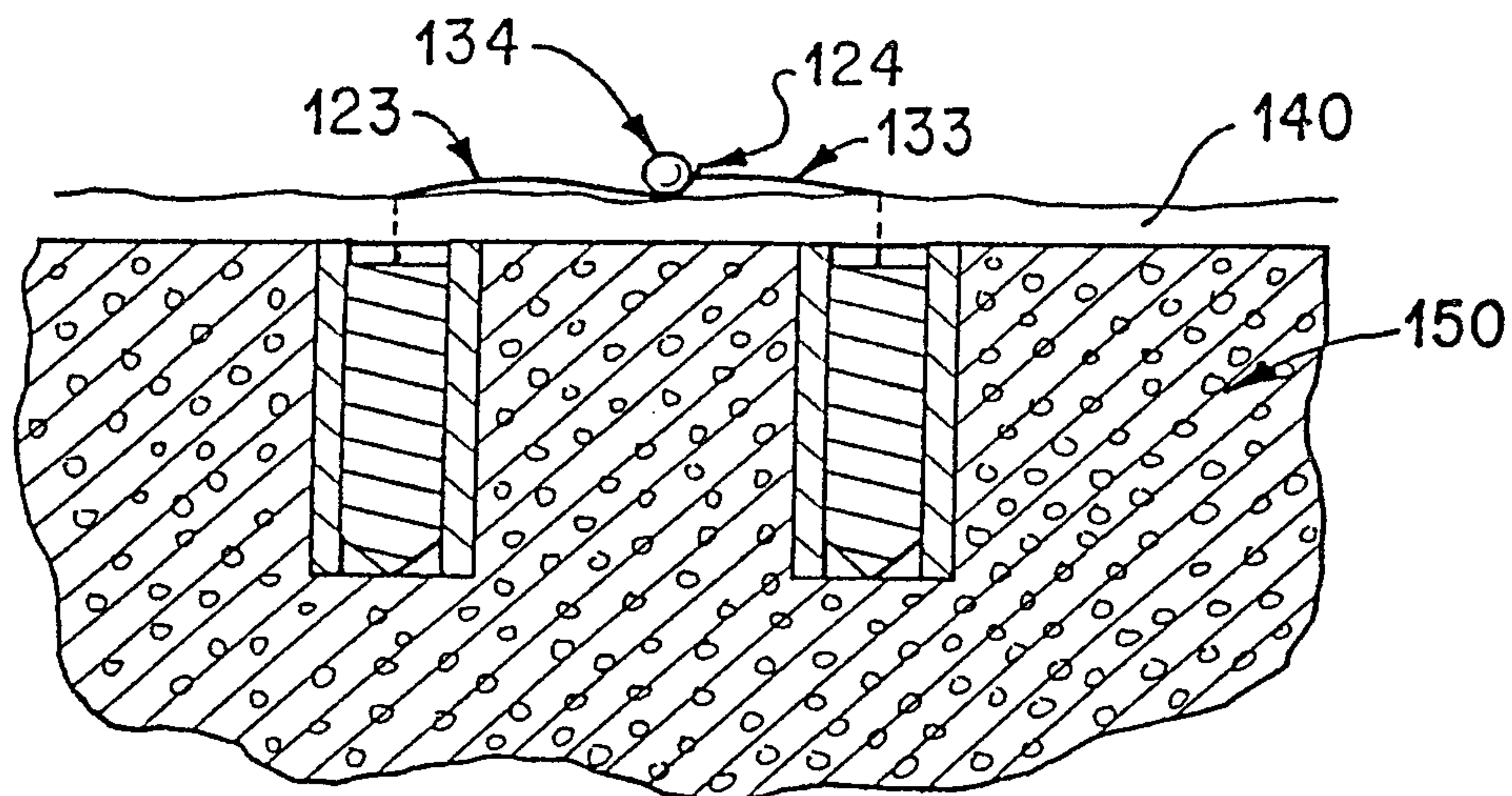

FIG. 11

6/11

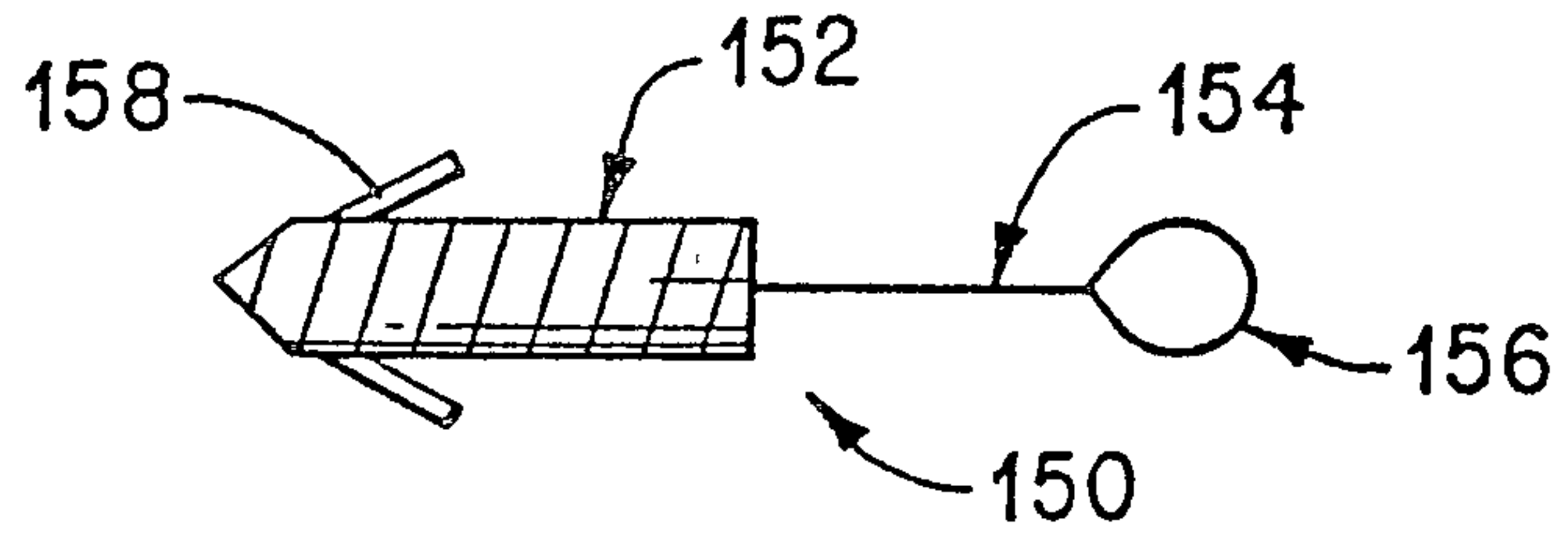

FIG. 12

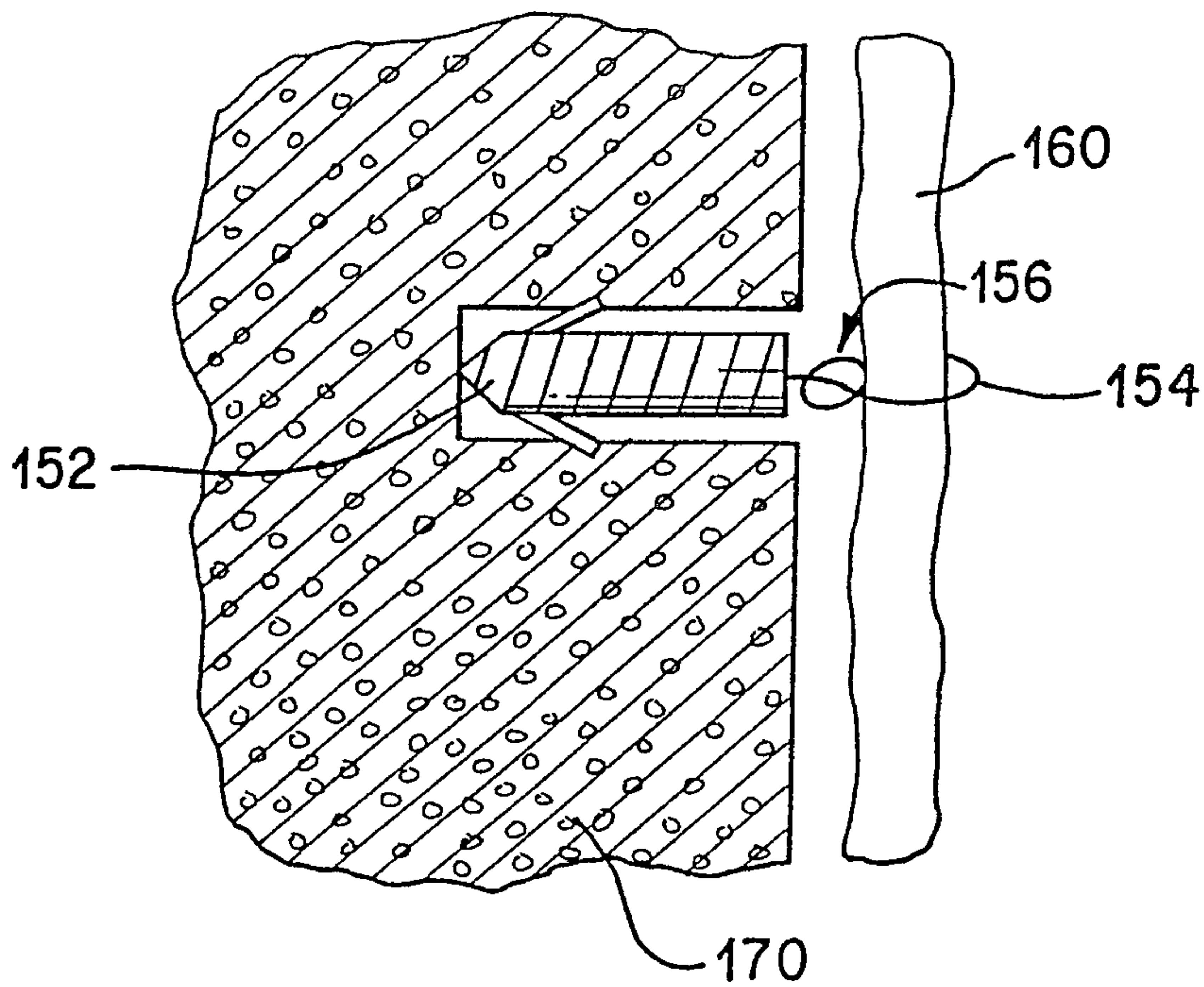

FIG. 13

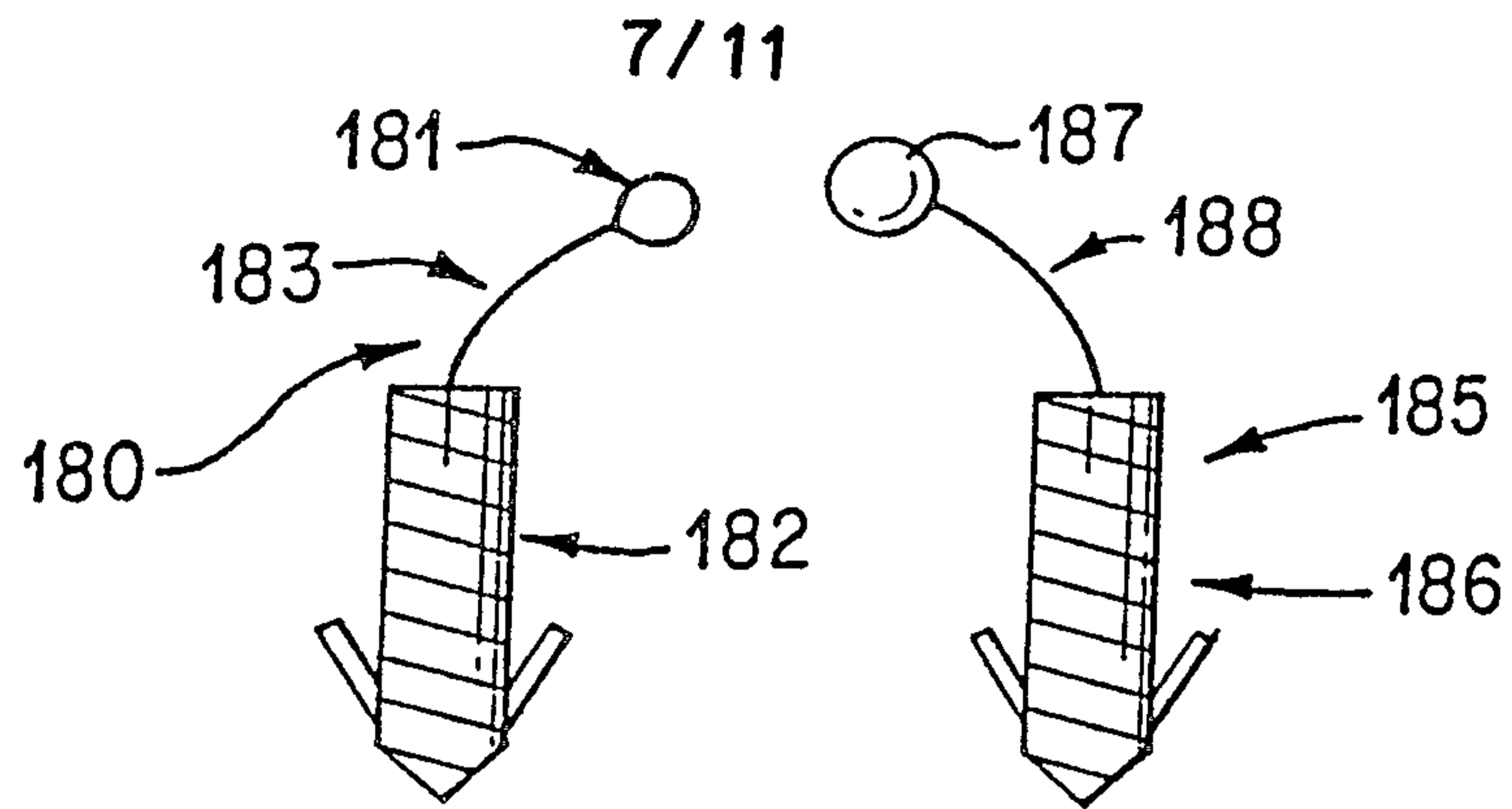

FIG. 14

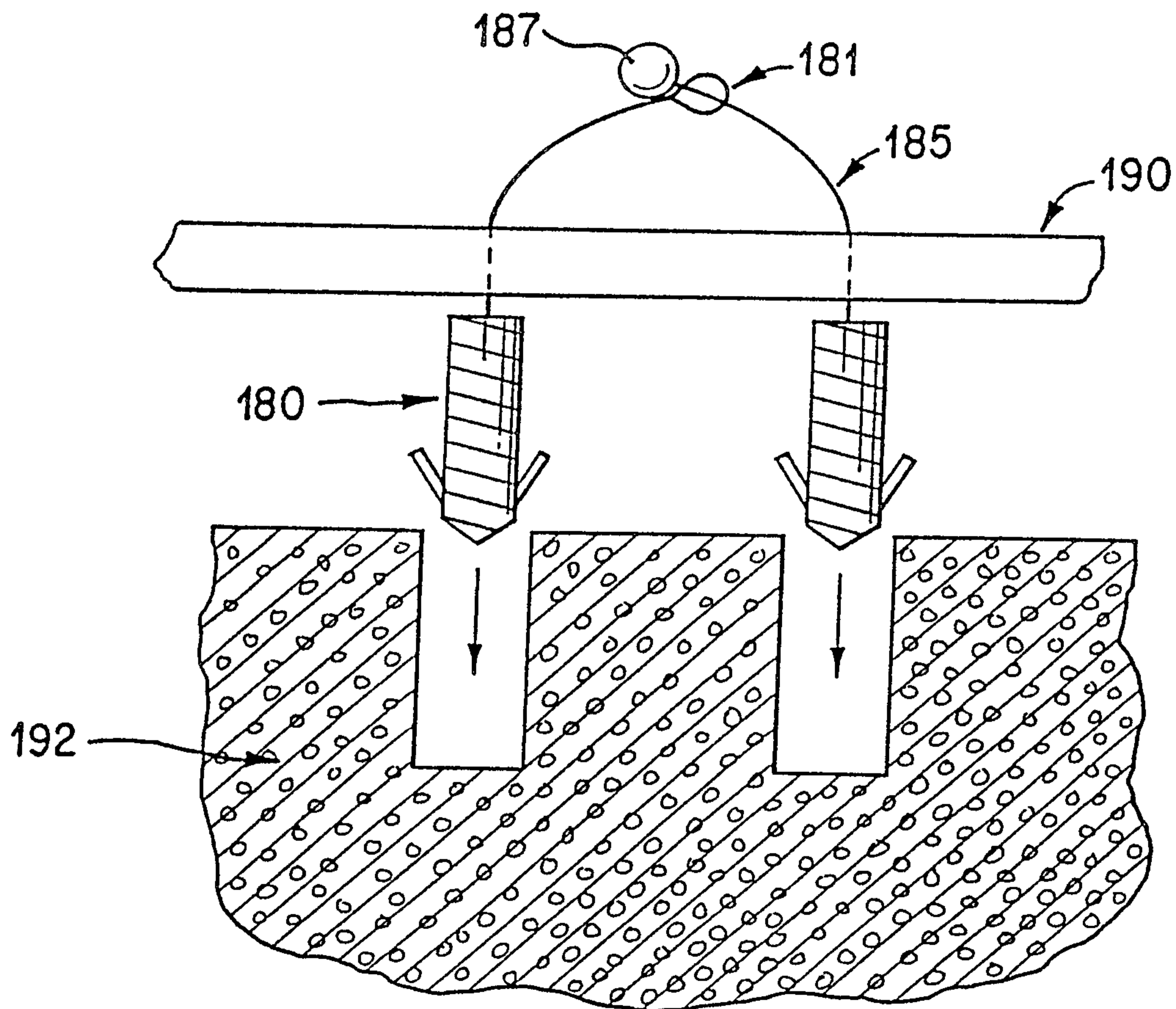

FIG. 15

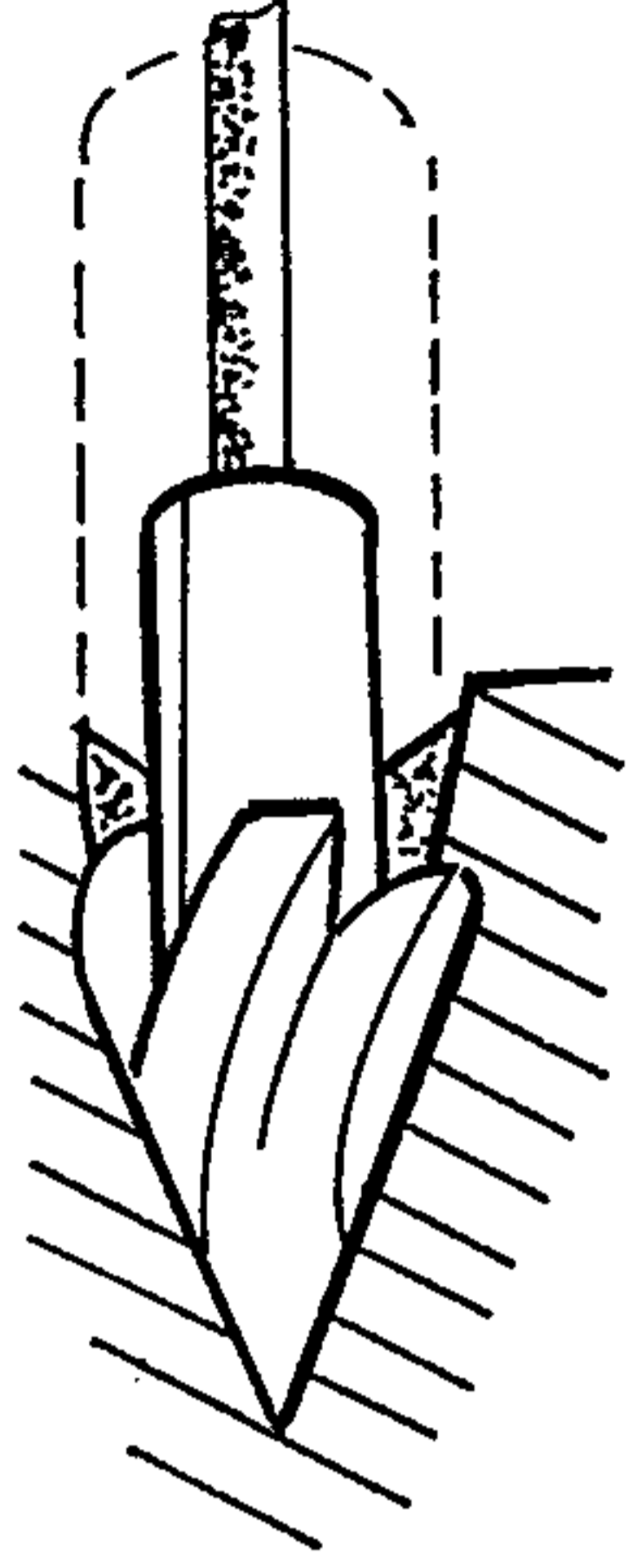

FIG. 16

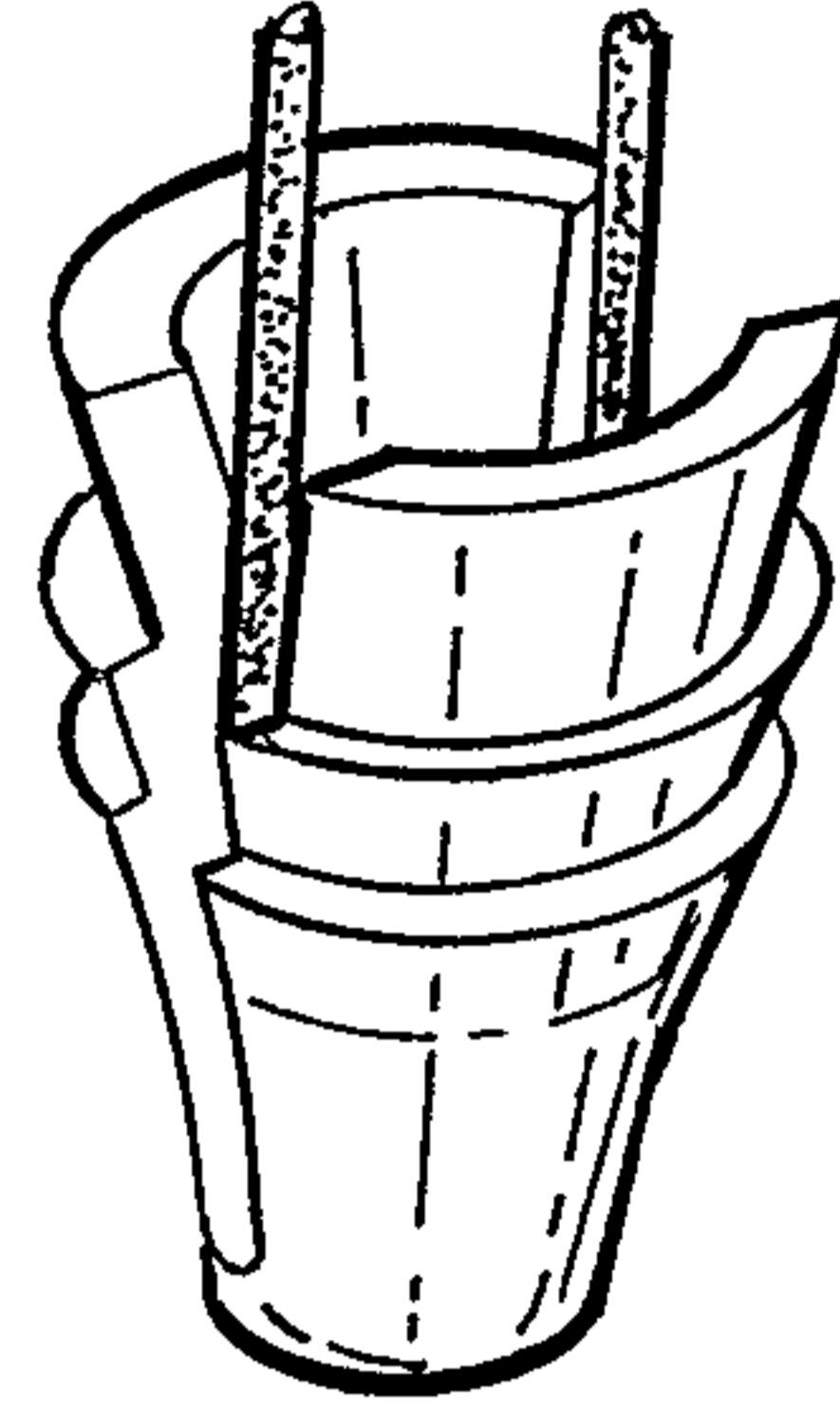

FIG. 17

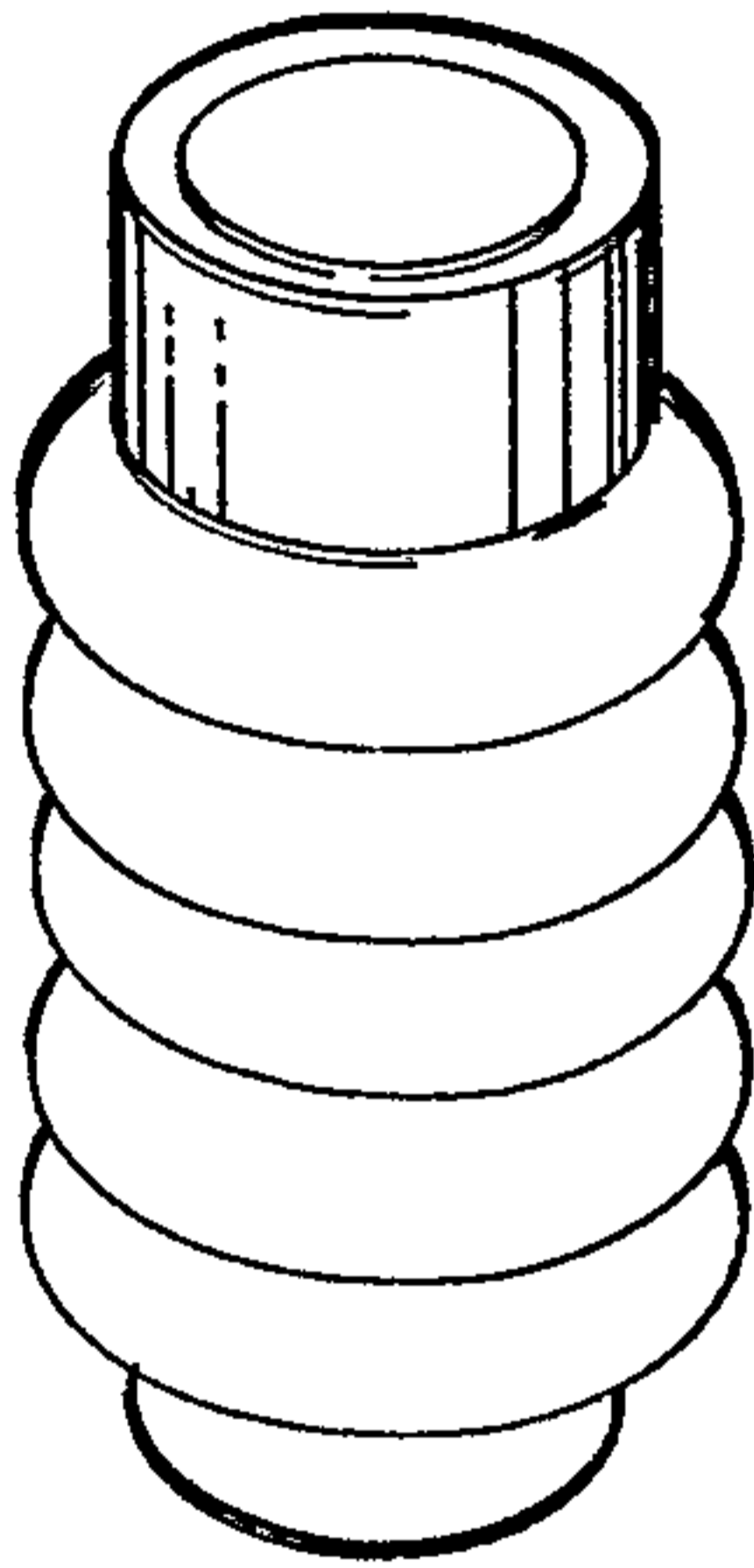

FIG. 18

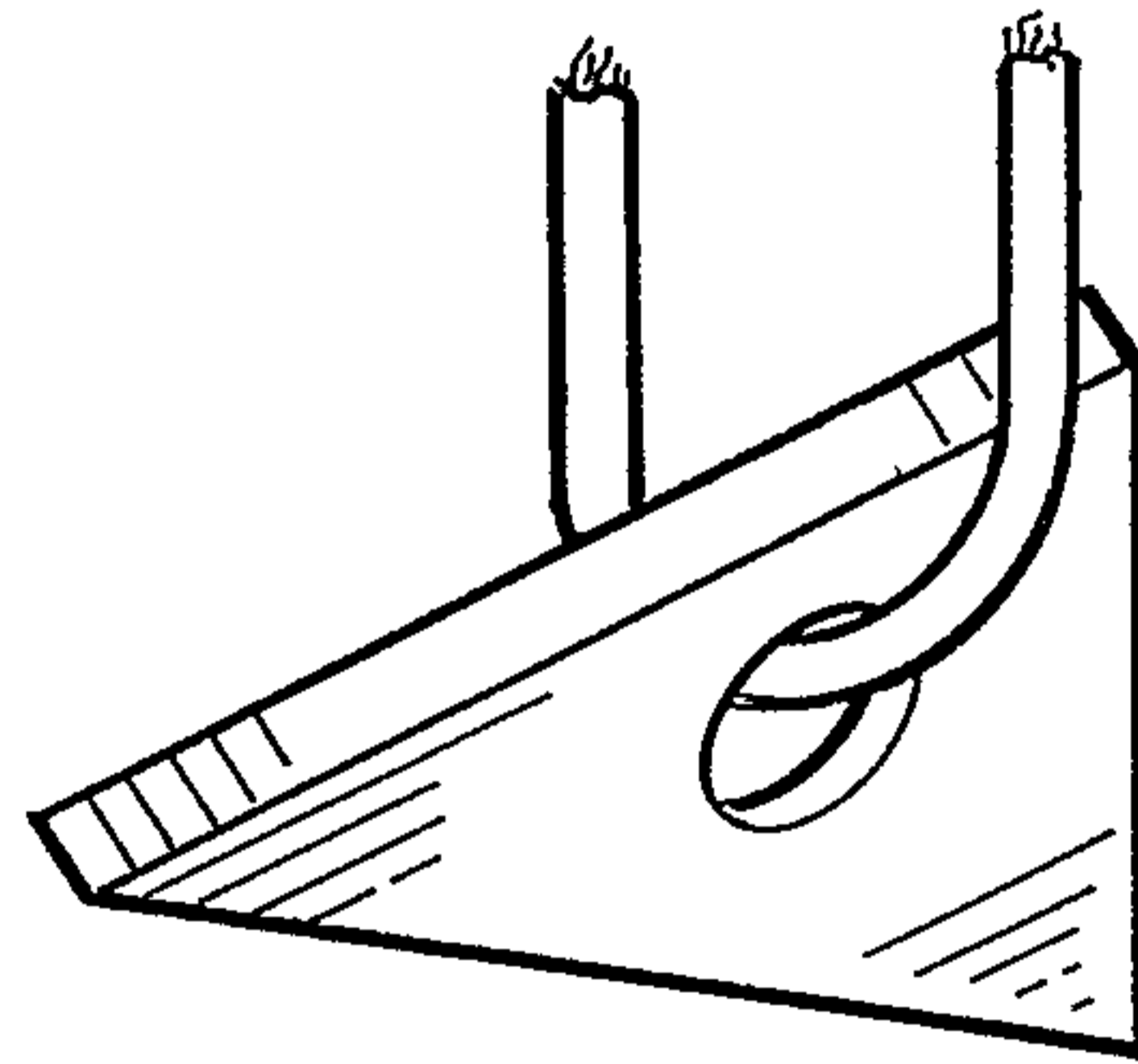

FIG. 19

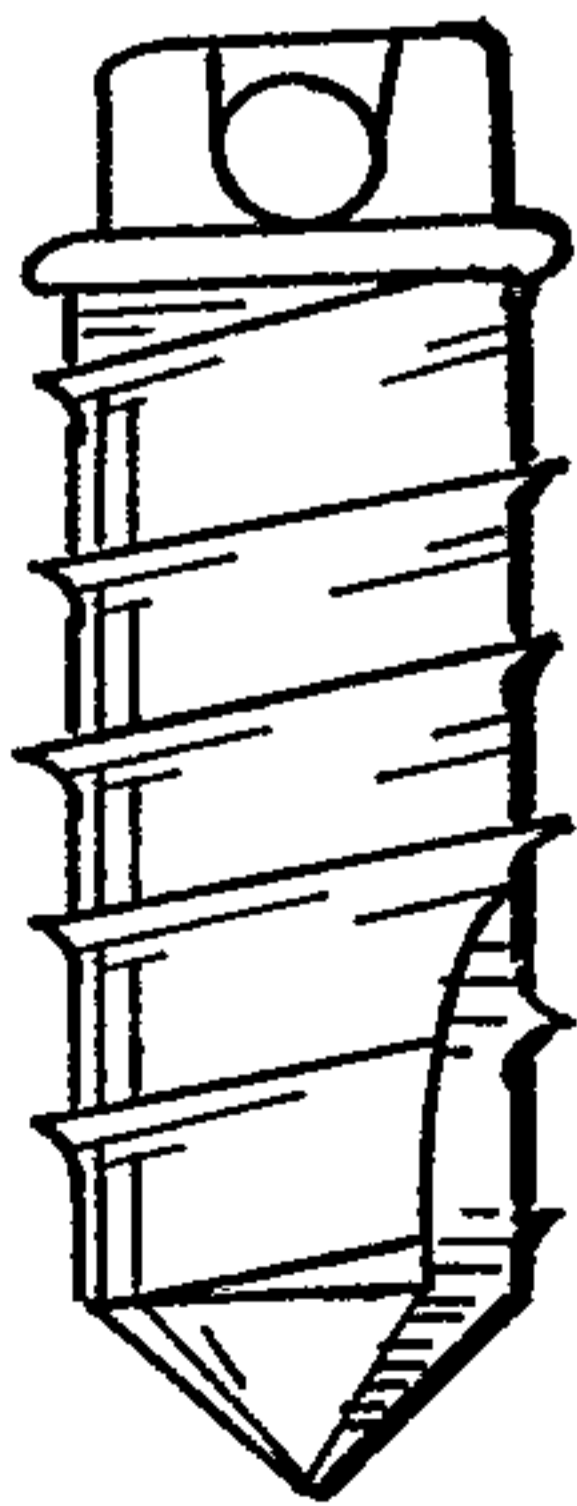

FIG. 20

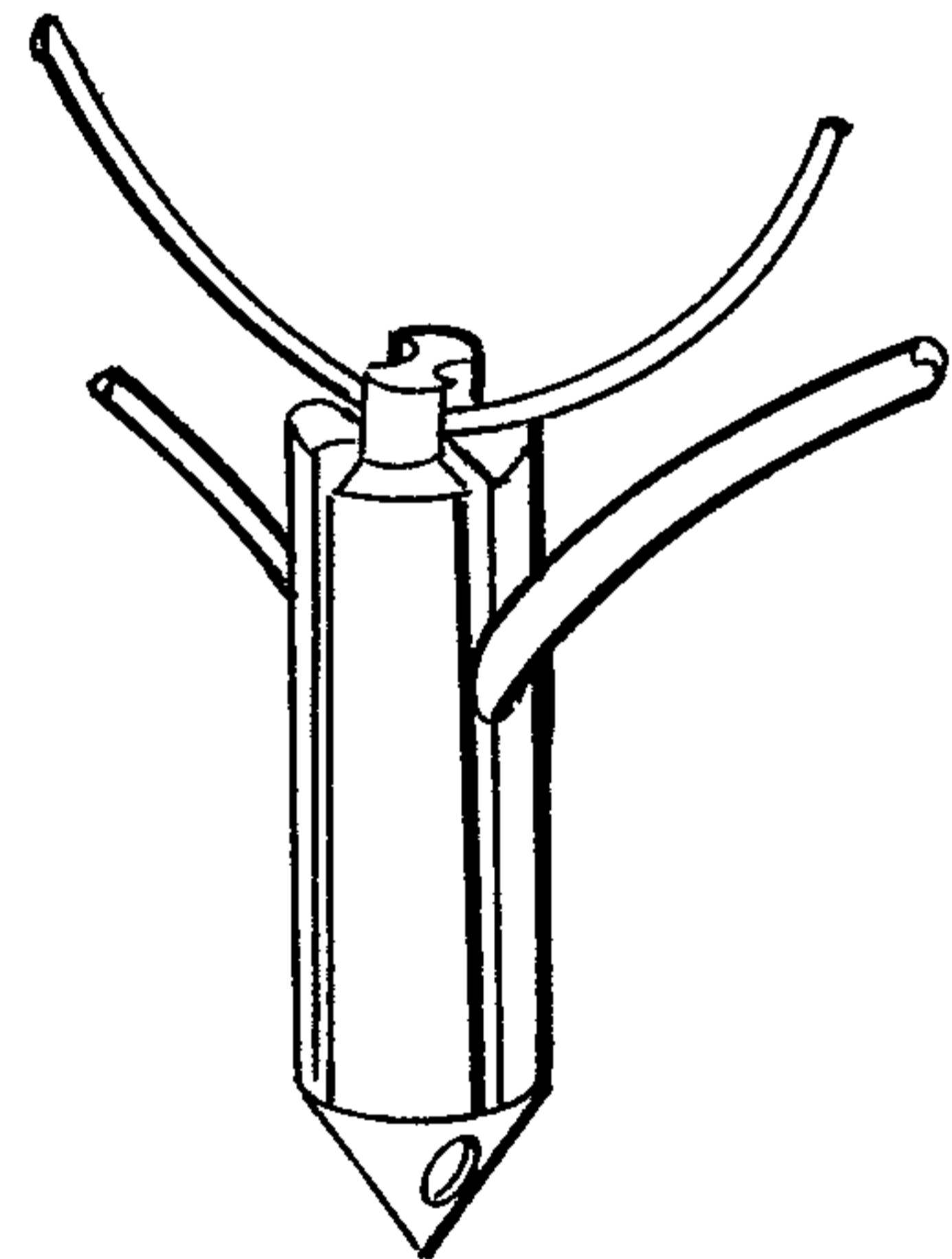

FIG. 21

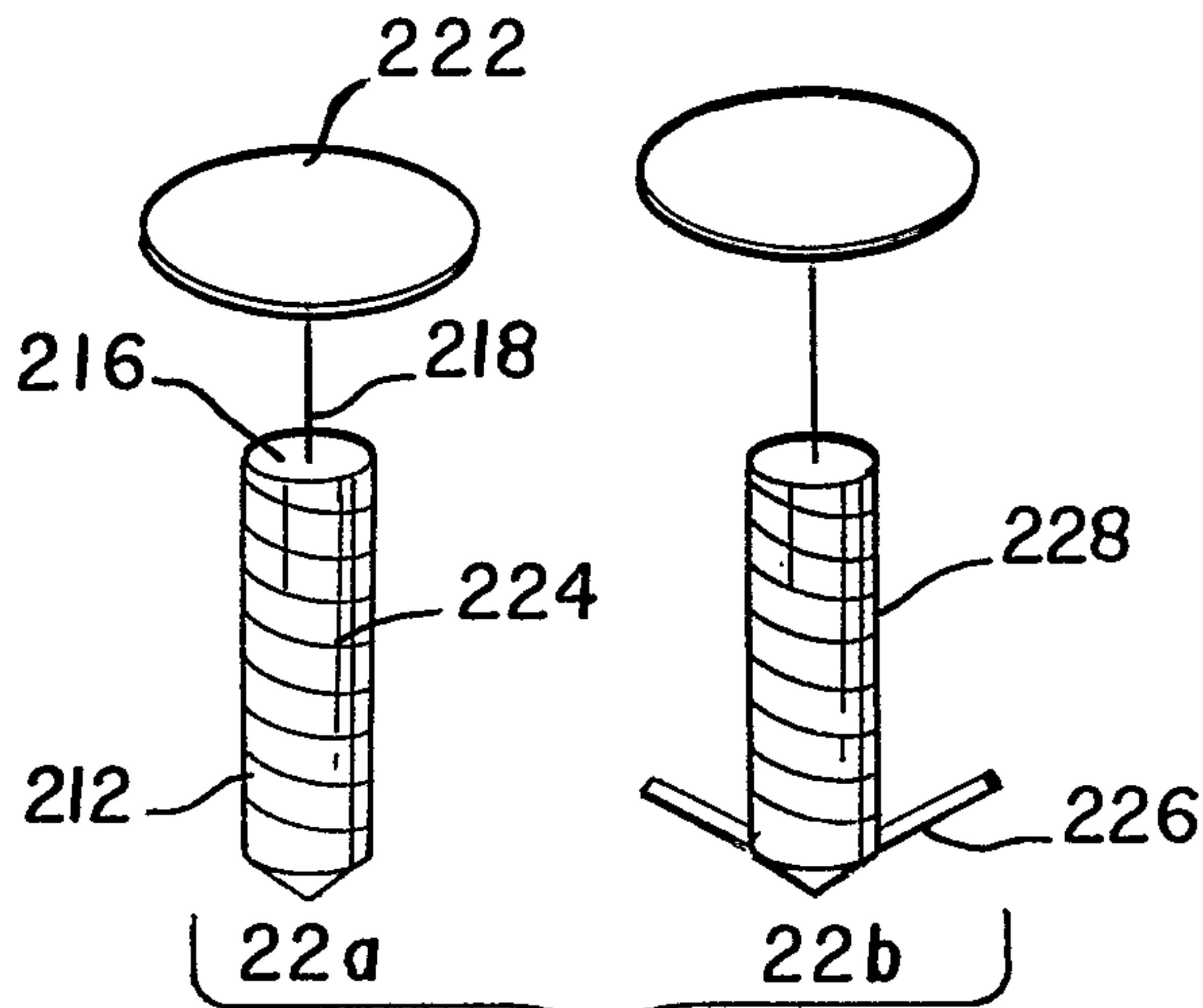

FIG. 22

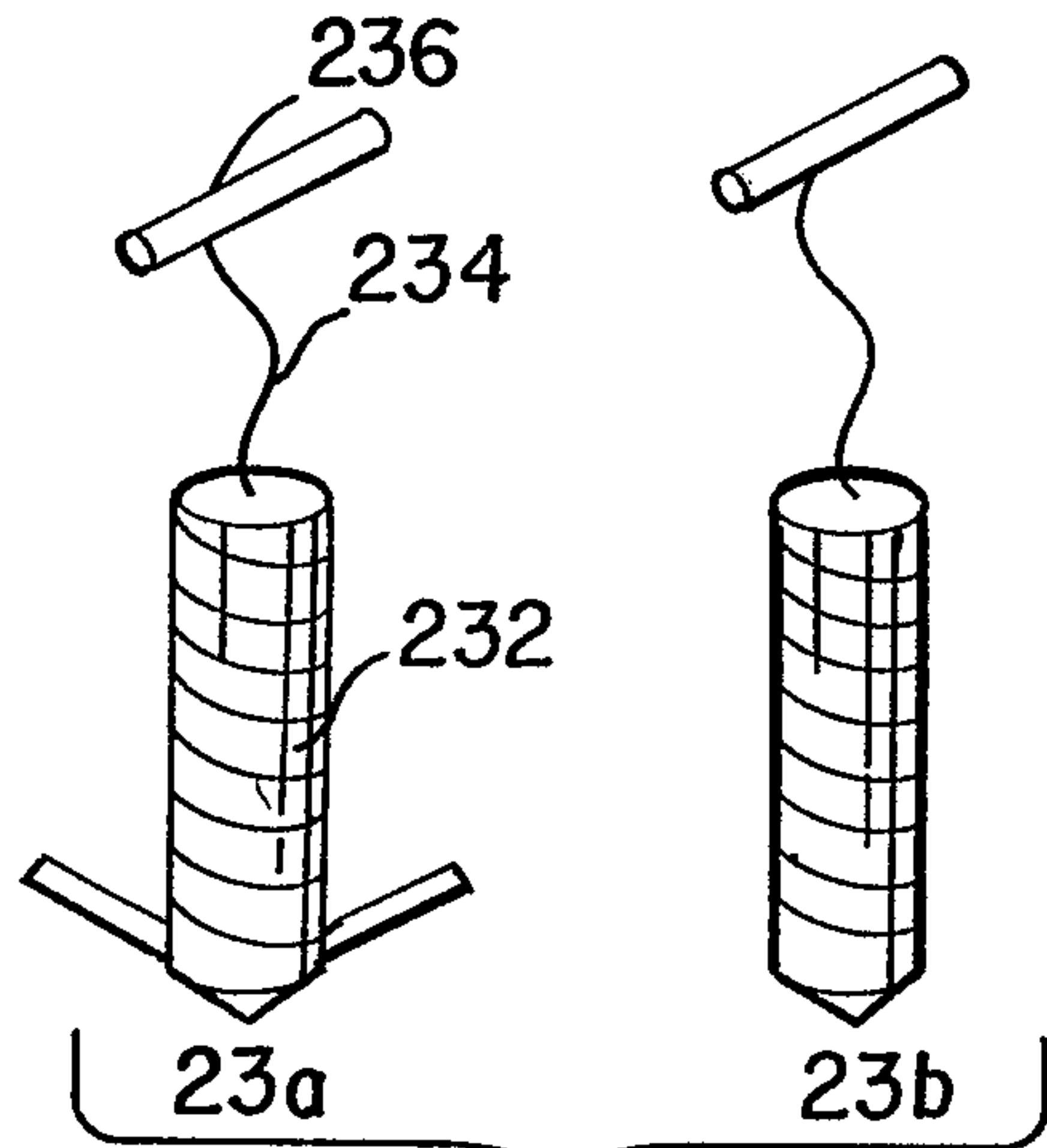

FIG. 23

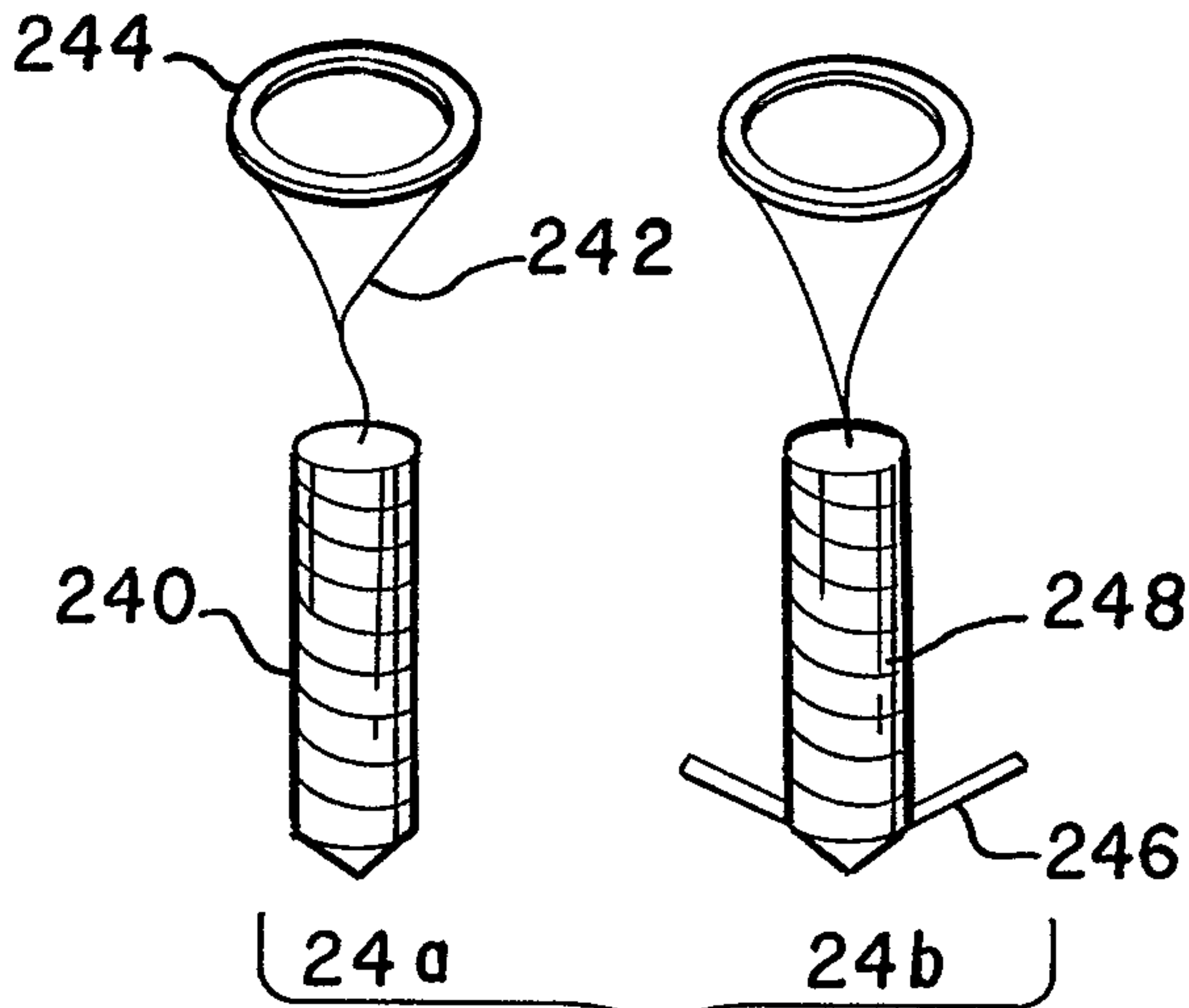

FIG. 24

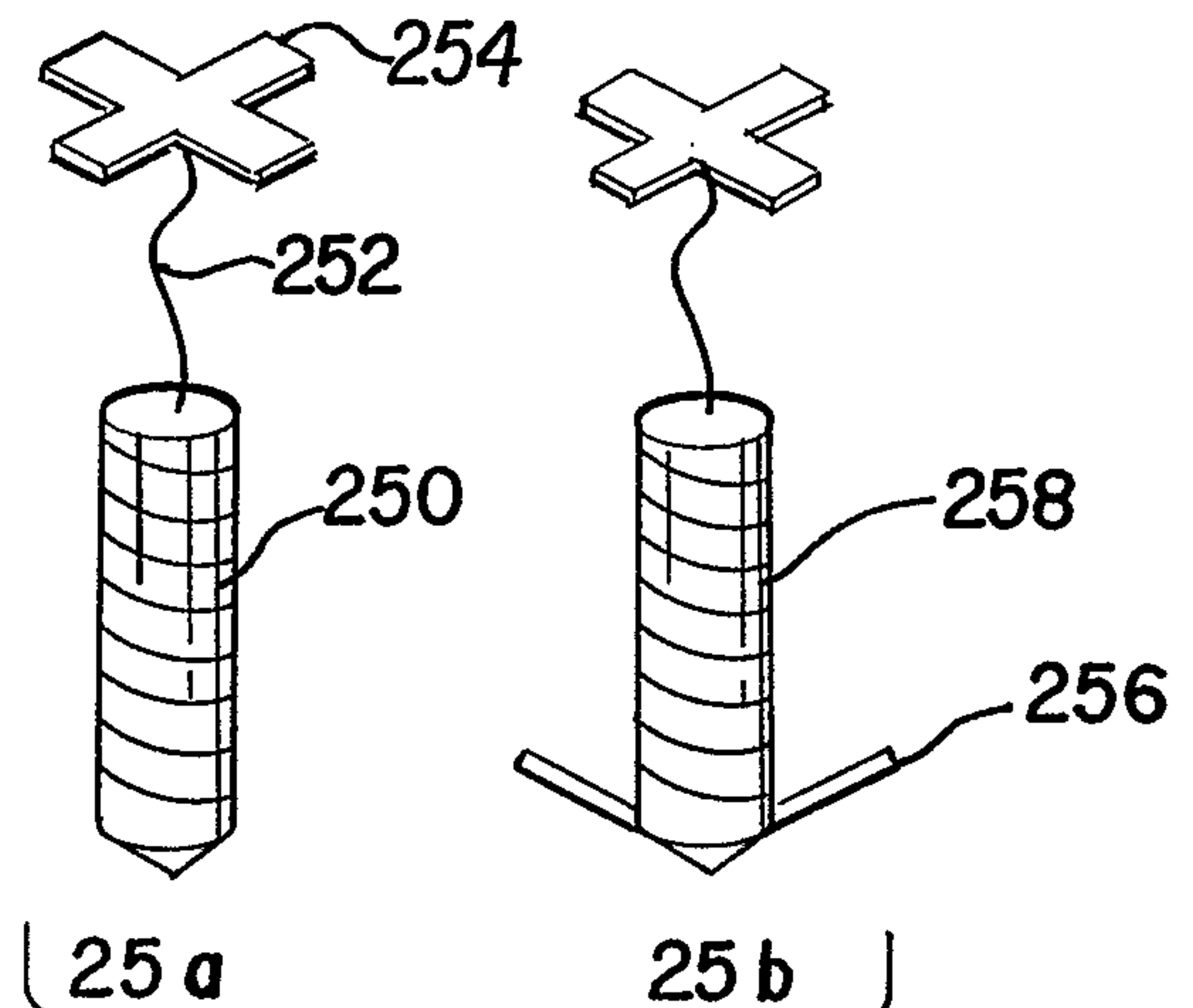

FIG. 25

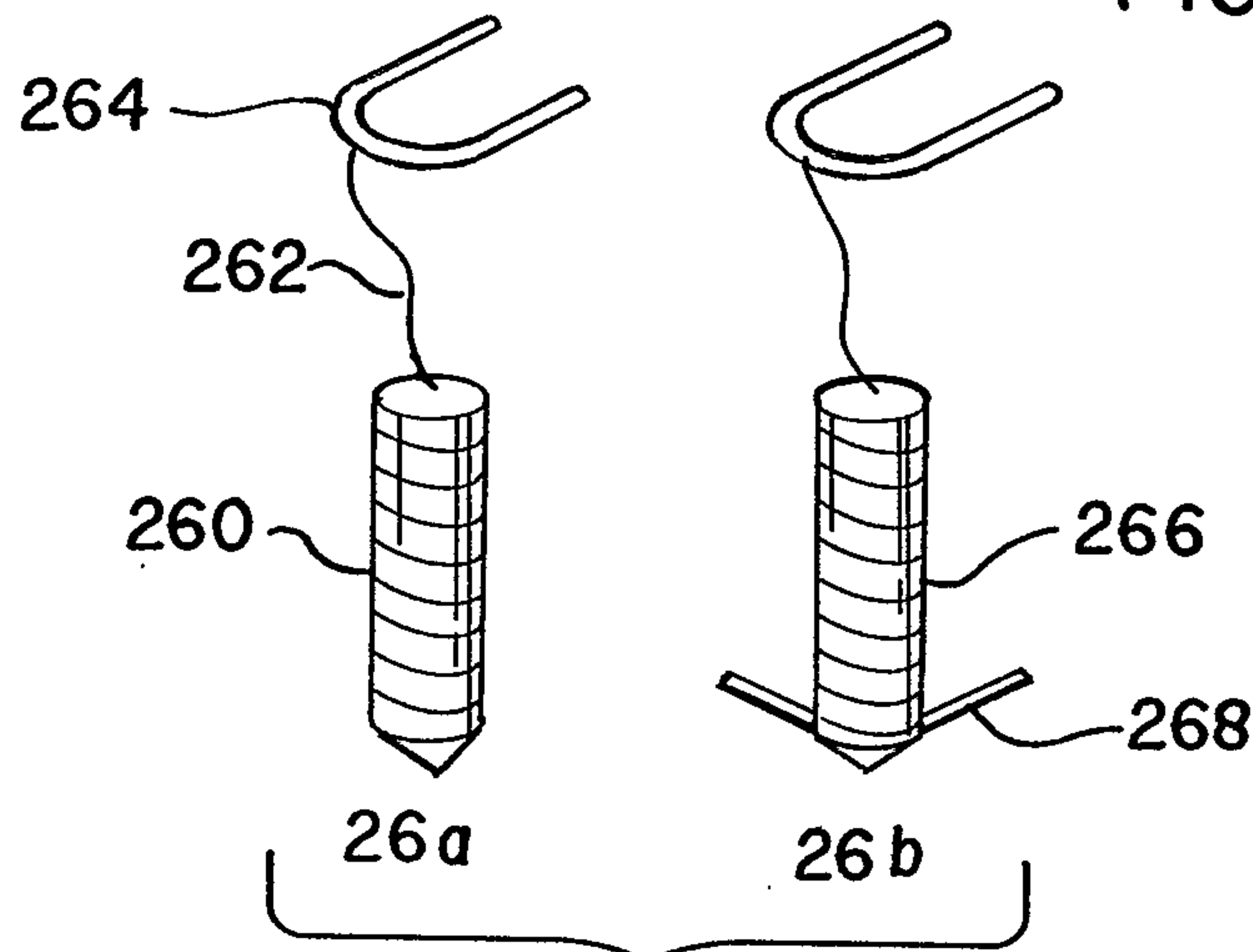

FIG. 26

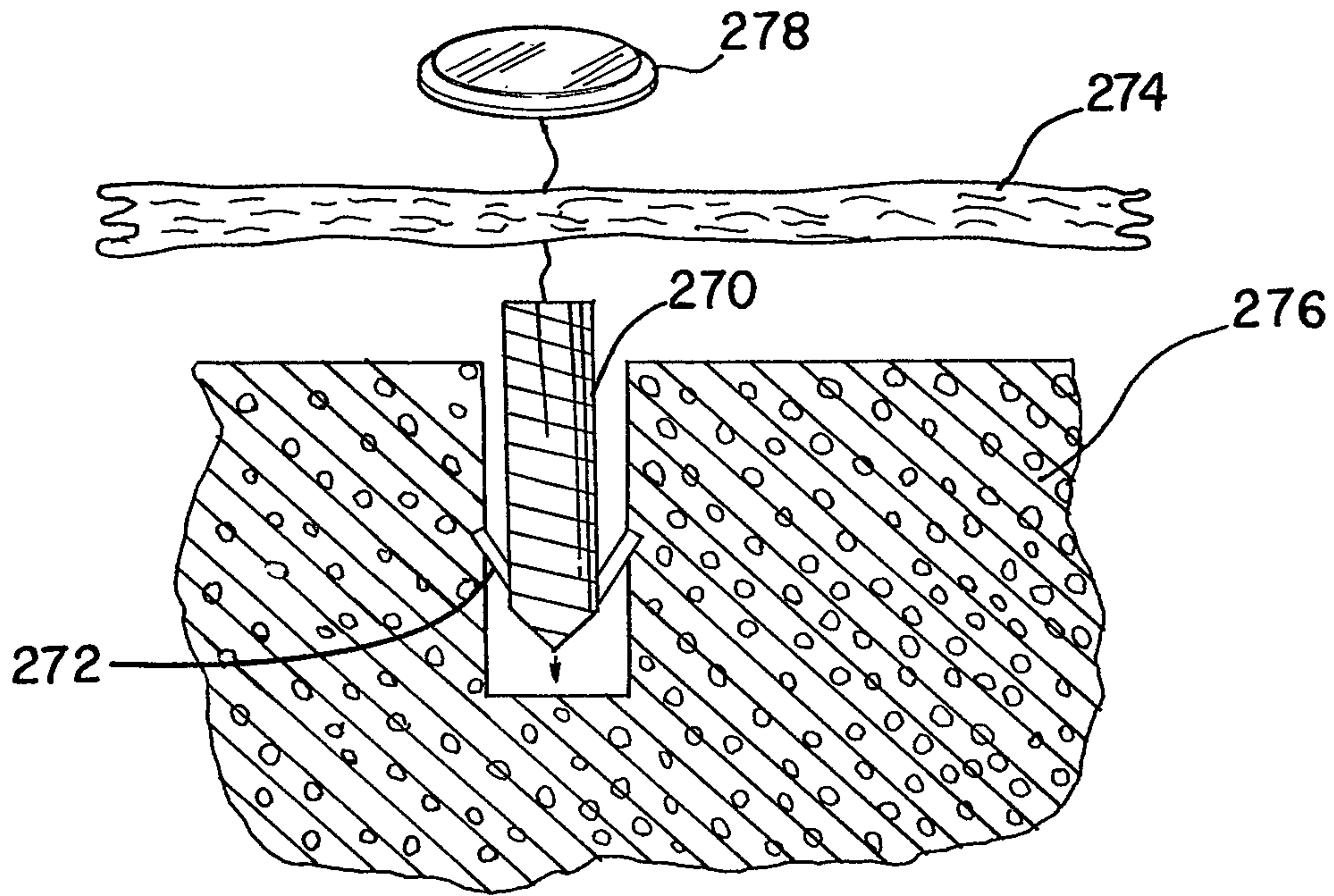

FIG. 27

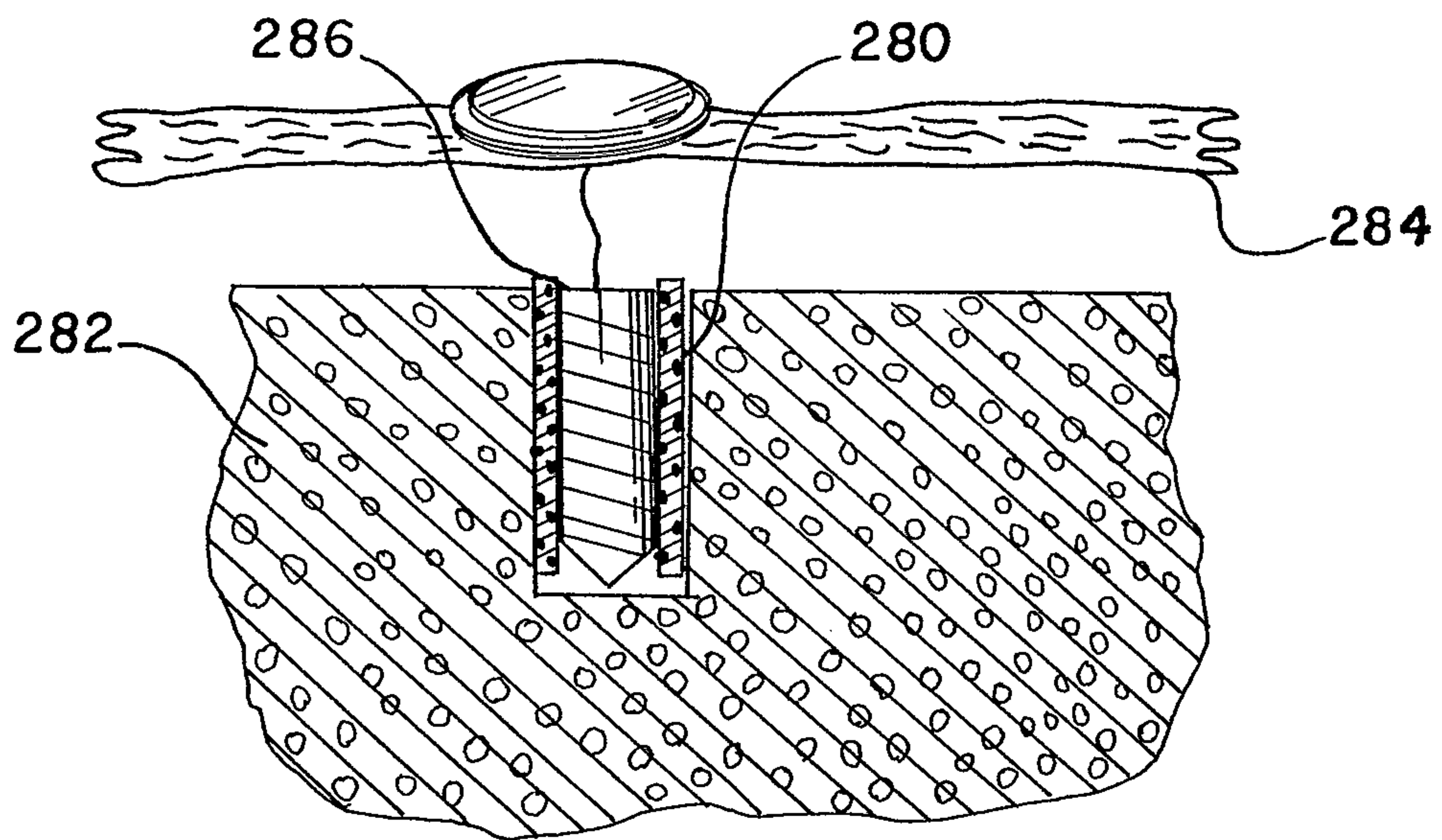

FIG. 28

11/11

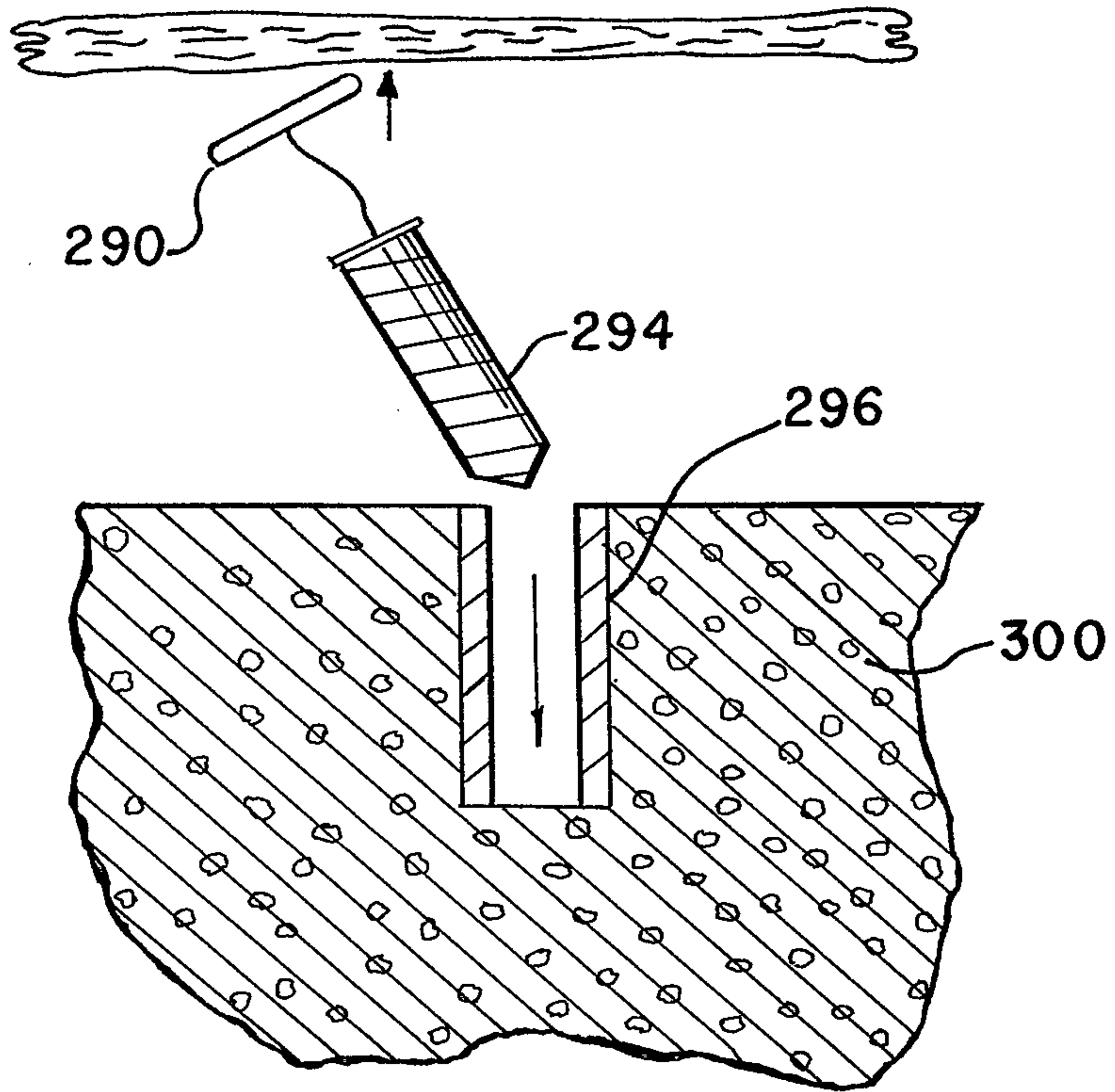

FIG. 29

